



KL PANEL XL



User Manual

©2022 ELATION PROFESSIONAL all rights reserved. Information, specifications, diagrams, images, and instructions herein are subject to change without notice. ELATION PROFESSIONAL logo and identifying product names and numbers herein are trademarks of ELATION PROFESSIONAL. Copyright protection claimed includes all forms and matters of copyrightable materials and information now allowed by statutory or judicial law or hereinafter granted. Product names used in this document may be trademarks or registered trademarks of their respective companies and are hereby acknowledged. All non-ELATION brands and product names are trademarks or registered trademarks of their respective companies.

ELATION PROFESSIONAL and all affiliated companies hereby disclaim any and all liabilities for property, equipment, building, and electrical damages, injuries to any persons, and direct or indirect economic loss associated with the use or reliance of any information contained within this document, and/or as a result of the improper, unsafe, insufficient and negligent assembly, installation, rigging, and operation of this product.

Elation Professional USA | 6122 S. Eastern Ave. | Los Angeles, CA. 90040
323-582-3322 | 323-832-9142 fax | www.elationlighting.com | info@elationlighting.com

Elation Professional B.V. | Junostraat 2 | 6468 EW Kerkrade, The Netherlands
+31 45 546 85 66 | +31 45 546 85 96 fax | www.elationlighting.eu | info@elationlighting.eu

Elation Professional Mexico | AV Santa Ana 30 | Parque Industrial Lerma, Lerma, Mexico 52000
+52 (728) 282-7070

DOCUMENT VERSION



Due to additional product features and/or enhancements, an updated version of this document may be available online. Please scan the QR Code with your mobile device or visit www.elationlighting.com for the latest revision/update of this manual, before installation and/or programming.

Date	Document Version	Software Version	DMX Channel Mode	Notes
09/22/21	1.0	1.07	1/4/7/6/12/48/96/24/ 14/23/58/4/12 Ch	Initial Release
11/03/21	1.1	N/C	No Change	Added Pixel Zones section
12/20/21	1.2	N/C	No Change	Updated Accessory Installation to include Intensifier Lens
02/08/22	1.3	N/C	No Change	Updated Accessories List
04/25/22	1.4	N/C	No Change	Updated Dimensional Drawings and Specifications

CONTENTS

General Information	4
Limited Warranty	5
Safety Guidelines	6
Maintenance Guidelines	8
Fixture Overview	9
Installation Instructions	10
Fixture Installation	11
Accessory Installation	12
Battery Connection	16
System Menu	17
Manual Mode	21
DMX Channel Functions and Values	23
Color Temperature Table	46
Virtual Swatch Book	47
Refresh Rate Table	48
Dimmer Modes	49
Pixel Zones	50
Specifications	51
Dimensional Drawings	52
Optional Accessories FCC Statement	53

GENERAL INFORMATION

INTRODUCTION

Please read and understand the instructions in this manual carefully and thoroughly before attempting to operate this device. These instructions contain important safety and use information. **For professional use only**

UNPACKING

Every device has been thoroughly tested and has been shipped in perfect operating condition. Carefully check the shipping carton for damage that may have occurred during shipping. If the carton is damaged, carefully inspect the device for damage, and be sure all accessories necessary to install and operate the device have arrived intact. In the event that damage has been found or parts are missing, please contact our customer support team for further instructions. Please do not return this device to your dealer without first contacting customer support. Please do not discard the shipping carton in the trash. Please recycle whenever possible.

BOX CONTENTS

Fixture (x1)
Barndoor Assembly (x1)
Junior Pin (x1)
Power Cable (x1)
Barndoor Safety Cable (x1)

CUSTOMER SUPPORT

Contact ELATION Service for any product related service and support needs.
Also visit forums.elationlighting.com with questions, comments, or suggestions.

ELATION SERVICE USA - Monday - Friday 8:00am to 4:30pm PST
323-582-3322 | Fax 323-832-9142 | support@elationlighting.com

ELATION SERVICE EUROPE - Monday - Friday 08:30 to 17:00 CET
+31 45 546 85 63 | Fax +31 45 546 85 96 | support@elationlighting.eu

REPLACEMENT PARTS please visit parts.elationlighting.com



IMPORTANT NOTICE!

THERE ARE NO USER SERVICEABLE PARTS INSIDE THIS UNIT. DO NOT ATTEMPT ANY REPAIRS YOURSELF, AS DOING SO WILL VOID YOUR MANUFACTURER'S WARRANTY. DAMAGES RESULTING FROM MODIFICATIONS TO THIS FIXTURE AND/OR THE DISREGARD OF SAFETY INSTRUCTIONS AND GUIDELINES IN THIS MANUAL VOID THE MANUFACTURER'S WARRANTY AND ARE NOT SUBJECT TO ANY WARRANTY CLAIMS AND/OR REPAIRS.

LIMITED WARRANTY

- A. Elation Professional hereby warrants, to the original purchaser, Elation Professional products to be free of manufacturing defects in material and workmanship for a period of two years (730 days), and Elation Professional product rechargeable batteries to be free of manufacturing defects in material and workmanship for a period of six months (180 days), from the original date of purchase. This warranty excludes discharge lamps and all product accessories. This warranty shall be valid only if the product is purchased within the United States of America, including possessions and territories. It is the owner's responsibility to establish the date and place of purchase by acceptable evidence, at the time service is sought.
- B. For warranty service, send the product only to the Elation Professional factory. All shipping charges must be pre-paid. If the requested repairs or service (including parts replacement) are within the terms of this warranty, Elation Professional will pay return shipping charges only to a designated point within the United States. If any product is sent, it must be shipped in its original package and packaging material. No accessories should be shipped with the product. If any accessories are shipped with the product, Elation Professional shall have no liability what so ever for loss and/or or damage to any such accessories, nor for the safe return thereof.
- C. This warranty is void if the product serial number and/or labels are altered or removed; if the product is modified in any manner which Elation Professional concludes, after inspection, affects the reliability of the product; if the product has been repaired or serviced by anyone other than the Elation Professional factory unless prior written authorization was issued to purchaser by Elation Professional; if the product is damaged because not properly maintained as set forth in the product instructions, guidelines and/or user manual.
- D. This is not a service contract, and this warranty does not include any maintenance, cleaning or periodic check-up. During the periods as specified above, Elation Professional will replace defective parts at its expense, and will absorb all expenses for warranty service and repair labor by reason of defects in material or workmanship. The sole responsibility of Elation Professional under this warranty shall be limited to the repair of the product, or replacement thereof, including parts, at the sole discretion of Elation Professional. All products covered by this warranty were manufactured after January 1, 1990, and bare identifying marks to that effect.
- E. Elation Professional reserves the right to make changes in design and/or performance improvements upon its products without any obligation to include these changes in any products theretofore manufactured.
- F. No warranty, whether expressed or implied, is given or made with respect to any accessory supplied with the products described above. Except to the extent prohibited by applicable law, all implied warranties made by Elation Professional in connection with this product, including warranties of merchantability or fitness, are limited in duration to the warranty periods set forth above. And no warranties, whether expressed or implied, including warranties of merchantability or fitness, shall apply to this product after said periods have expired. The consumer's and/or dealer's sole remedy shall be such repair or replacement as is expressly provided above; and under no circumstances shall Elation Professional be liable for any loss and/or damage, direct and/or consequential, arising out of the use of, and/or the inability to use, this product.
- G. This warranty is the only written warranty applicable to Elation Professional products and supersedes all prior warranties and written descriptions of warranty terms and conditions heretofore published.

WARRANTY RETURNS

All returned service items whether under warranty or not, must be freight pre-paid and accompanied by a return authorization (R.A.) number. The R.A. number must be clearly written on the outside of the return package. A brief description of the problem as well as the R.A. number must also be written down on a piece of paper and included in the shipping container. If the unit is under warranty, you must provide a copy of your proof of purchase invoice. Items returned without an R.A. number clearly marked on the outside of the package will be refused and returned at customer's expense. You may obtain an R.A. number by contacting customer support.

SAFETY GUIDELINES

This fixture is a sophisticated piece of electronic equipment. To guarantee smooth operation, it is important to follow all instructions and guidelines in this manual. Elation Professional is not responsible for injury and/or damages resulting from the misuse of this fixture due to the disregard of the information printed in this manual. Only qualified and/or certified personnel should perform installation of this fixture and only the original rigging parts included with this fixture should be used for installation. Any modifications to the fixture and/or the included mounting hardware will void the original manufacturer's warranty and increase the risk of damage and/or personal injury.



PROTECTION CLASS 1 - FIXTURE MUST BE PROPERLY GROUNDED.



THERE ARE NO USER SERVICEABLE PARTS INSIDE THIS UNIT. DO NOT ATTEMPT ANY REPAIRS YOURSELF. DOING SO WILL VOID YOUR MANUFACTURER'S WARRANTY. DAMAGES RESULTING FROM MODIFICATIONS TO THIS DEVICE AND/OR THE DISREGARD OF SAFETY INSTRUCTIONS AND GUIDELINES IN THIS MANUAL VOID THE MANUFACTURER'S WARRANTY AND ARE NOT SUBJECT TO ANY WARRANTY CLAIMS AND/OR REPAIRS.



**DO NOT PLUG THIS UNIT INTO A DIMMER PACK!
NEVER OPERATE THIS UNIT WITH THE CASING REMOVED!
DISCONNECT POWER BEFORE PERFORMING MAINTENANCE!
NEVER TOUCH DURING OPERATION, AS FIXTURE SURFACES MAY BE HOT!
KEEP FLAMMABLE MATERIALS AWAY FROM FIXTURE!**



**NEVER LOOK DIRECTLY INTO THE LIGHT SOURCE!
RETINA INJURY RISK - MAY INDUCE BLINDNESS!
SENSITIVE PERSONS MAY SUFFER AN EPILEPTIC SHOCK!**



**FOR USE IN INDOOR OR DRY LOCATIONS ONLY!
DO NOT EXPOSE TO RAIN AND/OR MOISTURE!**

SAFETY GUIDELINES

- **DO NOT TOUCH** the fixture housing during operation.
- Turn OFF the power and allow approximately 15 minutes for the fixture to cool down before serving.
- **DO NOT** shake fixture and avoid brute force when installing and/or operating fixture.
- **DO NOT** operate fixture if the power cord is frayed, crimped, damaged, and/or if any of the power cord connectors are damaged and do not insert into the fixture securely with ease.
- **NEVER** force a power cord connector into the fixture. If the power cord or any of its connectors are damaged, replace it immediately with a new one of the same rating.
- **DO NOT** block any air ventilation slots.
- All fan and air inlets must remain clean and never blocked.
- Allow approx. 6" (15cm) between fixture and other devices or a wall for proper cooling.
- When installing fixture in a suspended environment, always use mounting hardware that is no less than M10 x 25 mm, and always install fixture with an appropriately rated safety cable.
- Always disconnect fixture from main power source before performing any type of service and/or cleaning procedure.
- Only handle the power cord by the plug end, and never pull out the plug by tugging the wire portion of the cord.
- During the initial operation of this fixture, a light smoke or smell may emit from the interior of the fixture. This is a normal process and is caused by excess paint in the interior of the casing burning off from the heat associated with the lamp and will decrease gradually over time.
- Consistent operational breaks will ensure fixture will function properly for many years.
- **ONLY** use the original packaging and materials to transport the fixture for service.

MAINTENANCE GUIDELINES



DISCONNECT POWER BEFORE PERFORMING ANY MAINTENANCE!

CLEANING

Frequent cleaning is recommended to ensure proper function, optimized light output, and an extended life. The frequency of cleaning depends on the environment in which the fixture operates: damp, smoky, or particularly dirty environments can cause greater accumulation of dirt on the fixture's optics. Clean periodically with a soft cloth to avoid dirt/debris accumulation.

NEVER use alcohol, solvents, or ammonia-based cleaners.

MAINTENANCE

Regular inspections are recommended to ensure proper function and extended life. There are no user serviceable parts inside this fixture. Please refer all service issues to an authorized Elation service technician. Should you need any spare parts, please order genuine parts from an authorized Elation dealer.

Please refer to the following points during routine inspections:

- A detailed electrical check by an approved electrical engineer every three months, to make sure the circuit contacts are in good condition and prevent overheating.
- Be sure all screws and fasteners are securely tightened at all times. Loose screws may fall out during normal operation, resulting in damage or injury as larger parts could fall.
- Check for any deformations on the housing, color lenses, rigging hardware, and rigging points (ceiling, suspension, trussing). Deformations in the housing could allow for dust to enter into the fixture. Damaged rigging points or unsecured rigging could cause the fixture to fall and seriously injure a person(s).
- Electric power supply cables must not show any damage, material fatigue, or sediments.

NEVER remove the ground prong from the power cable.

FIXTURE OVERVIEW

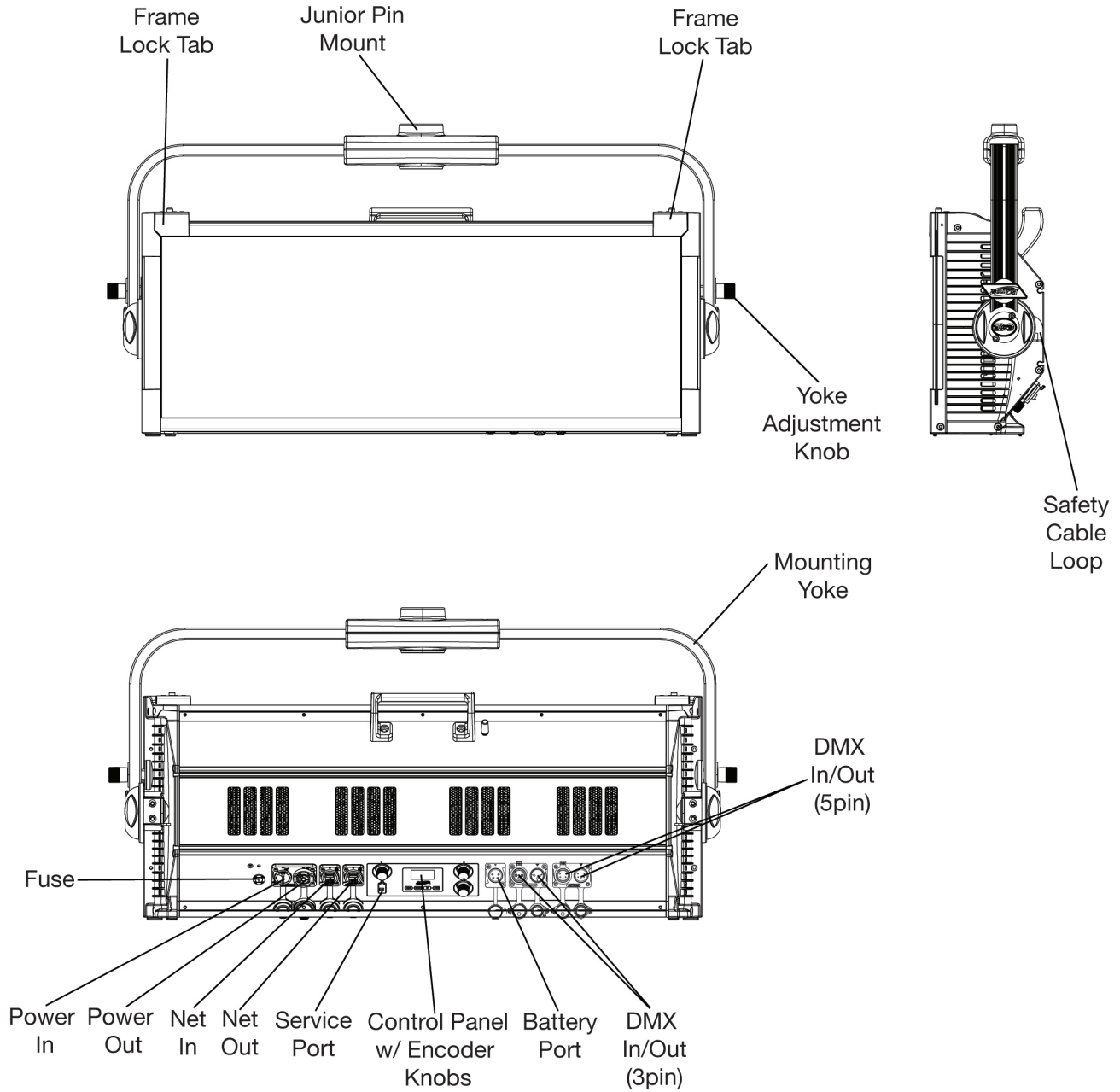

INSTALLATION INSTRUCTIONS



FLAMMABLE MATERIAL WARNING

Keep fixture minimum 5.0 feet (1.5m) away from flammable materials and/or pyrotechnics.



ELECTRICAL CONNECTIONS

A qualified electrician should be used for all electrical connections and/or installations.



DO NOT PERFORM THE INSTALLATION YOURSELF IF YOU ARE NOT QUALIFIED TO DO SO!

WHEN RUNNING ON 110V POWER, THE UNITS MAY NOT BE LINKED TOGETHER VIA THE POWER INPUT/OUTPUT TERMINALS! EACH UNIT MUST BE INDEPENDENTLY CONNECTED TO A POWER SOURCE!

When running on 240V power, however, up to 4 units may be linked together via the power input/output terminals. Once this values has been reached, a new power outlet must be used to accommodate additional units. All linked units **MUST** be of the same make and model type. **DO NOT MIX UNITS!**

Fixture **MUST** be installed following all local, national, and country commercial electrical and construction codes and regulations.

Before rigging/mounting a single fixture or multiple fixtures to any metal truss/structure or placing the fixture(s) on any surface, a professional equipment installer **MUST** be consulted to determine if the metal truss/structure or surface is properly certified to safely hold the combined weight of the fixture(s), clamps, cables, and accessories.

Maximum fixture ambient operating temperature is **113°F (45°C)**. Do not operate this fixture when ambient temperature exceeds this rating.

Fixture(s) should be installed in areas outside walking paths, seating areas, or away from areas where unauthorized personnel might reach the fixture by hand.

NEVER stand directly below the fixture(s) when rigging, removing, or servicing.

Overhead fixture installation must always be secured with a secondary safety attachment, such as an appropriately rated safety cable.

Allow approximately 15 minutes for the fixture to cool down before serving.

FIXTURE INSTALLATION

CLAMP INSTALLATION

A junior pin can be attached to the mounting surface on the fixture's mounting yoke, and this junior pin can then be used as an attachment point for a mounting clamp. Details on junior pin installation can be found in the **Accessory Installation** section of this manual.

The device also features a safety cable loop on mounting yoke hinge nearest to the DMX ports (see the illustration below for reference). When mounting the fixture to a truss or any other suspended or overhead installation, be sure to secure an appropriately rated clamp (not included) to the junior pin and attach a separate **SAFETY CABLE** of the appropriate safety rating to the safety cable rigging point. In the event that the optional barn doors are installed on this fixture, a secondary **SAFETY CABLE** is also required to be attached to the barn doors, as shown in the image below. For information on barn door installation, please refer to the **Accessory Installation** section of this manual.

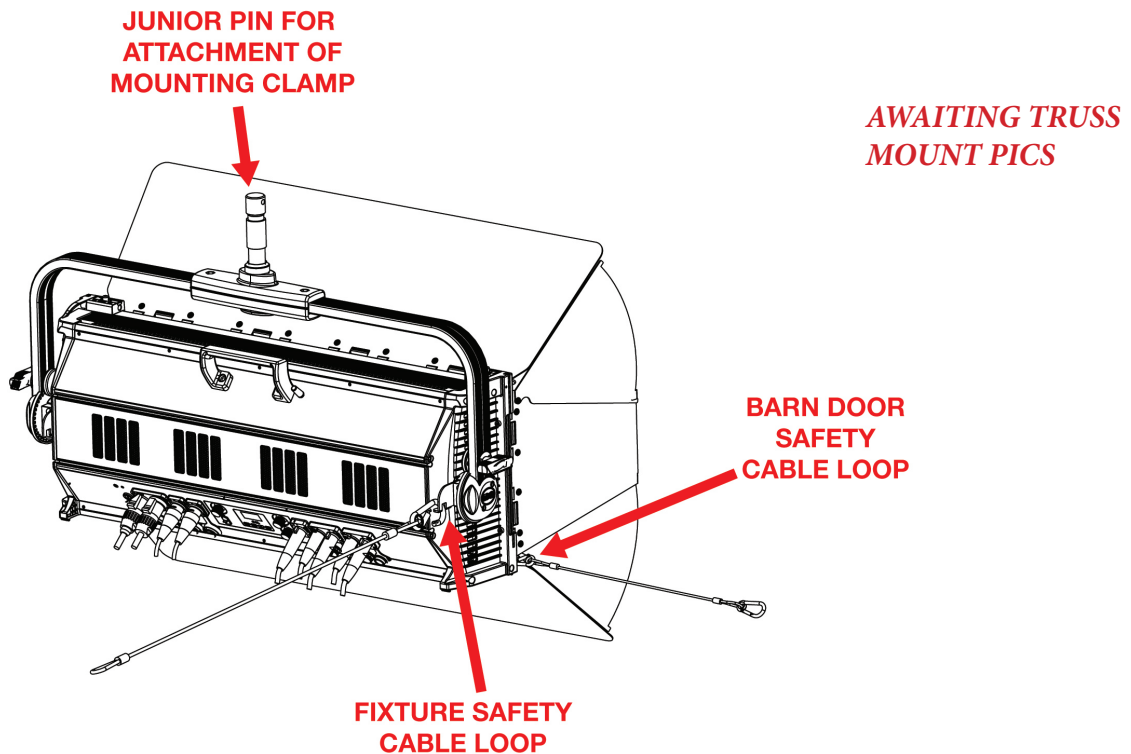

ALWAYS ATTACH A SAFETY CABLE WHENEVER INSTALLING THIS FIXTURE IN A SUSPENDED ENVIRONMENT TO ENSURE THAT THE FIXTURE WILL NOT FALL IF THE CLAMP FAILS.

RIGGING

Overhead rigging requires extensive experience, including but not limited to: calculating working load limits, understanding the installation material being used, and periodic safety inspection of all installation material and the fixture itself. If you lack these qualifications, do not attempt to perform the installation yourself. Improper installation can result in bodily injury.

ACCESSORY INSTALLATION

JUNIOR PIN INSTALLATION

To install the junior pin to the mounting point on the yoke, orient the junior pin with the notched end facing the yoke mounting point. Align the notch on the junior pin with the matching groove on the yoke mounting point. Then, insert the fastener from the other side of the yoke mounting point, making sure that the fastener goes through both the yoke and the junior pin, and tighten the fastener securely. The junior pin should now be securely installed.

See the picture below for reference:

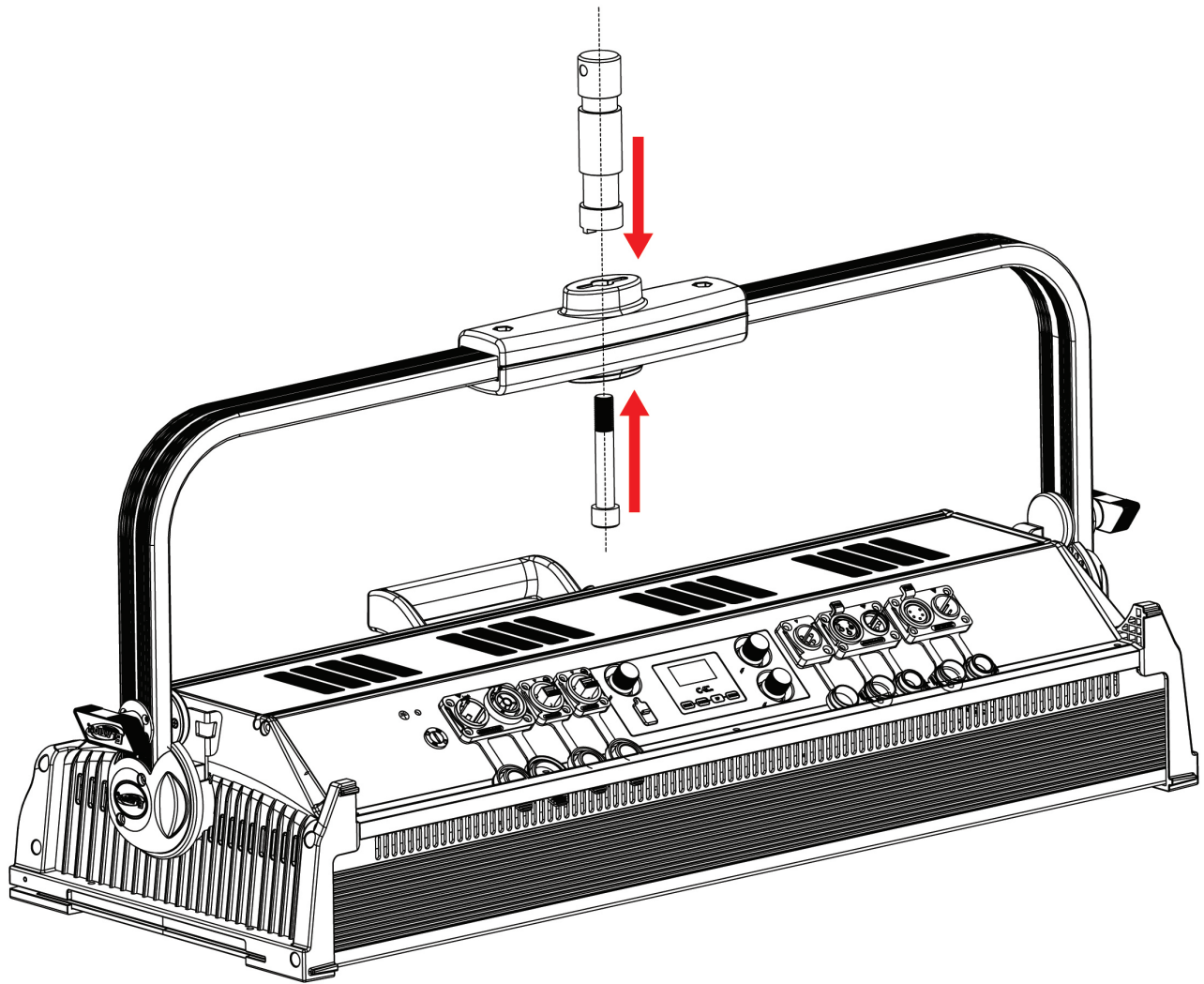

ACCESSORY INSTALLATION

STAND MOUNT INSTALLATION

This device is capable of being stand mounted by following the steps below:

1. Install the Junior Pin, as detailed elsewhere in this section.
2. Lock the mounting bracket in place by tightening both bracket knobs.
3. Insert the Junior Pin into the top of the Tripod Stand. Align the through-hole on the Junior Pin with the holes in the top of the Tripod Stand, then insert the Locking Pin through the hole and fasten in place.
4. If necessary, loosen the bracket knobs, adjust the fixture to the desired position, then tighten the bracket knobs to lock the fixture in place. Use caution to prevent the Tripod Stand from tipping over during adjustment.

See the picture below for reference:

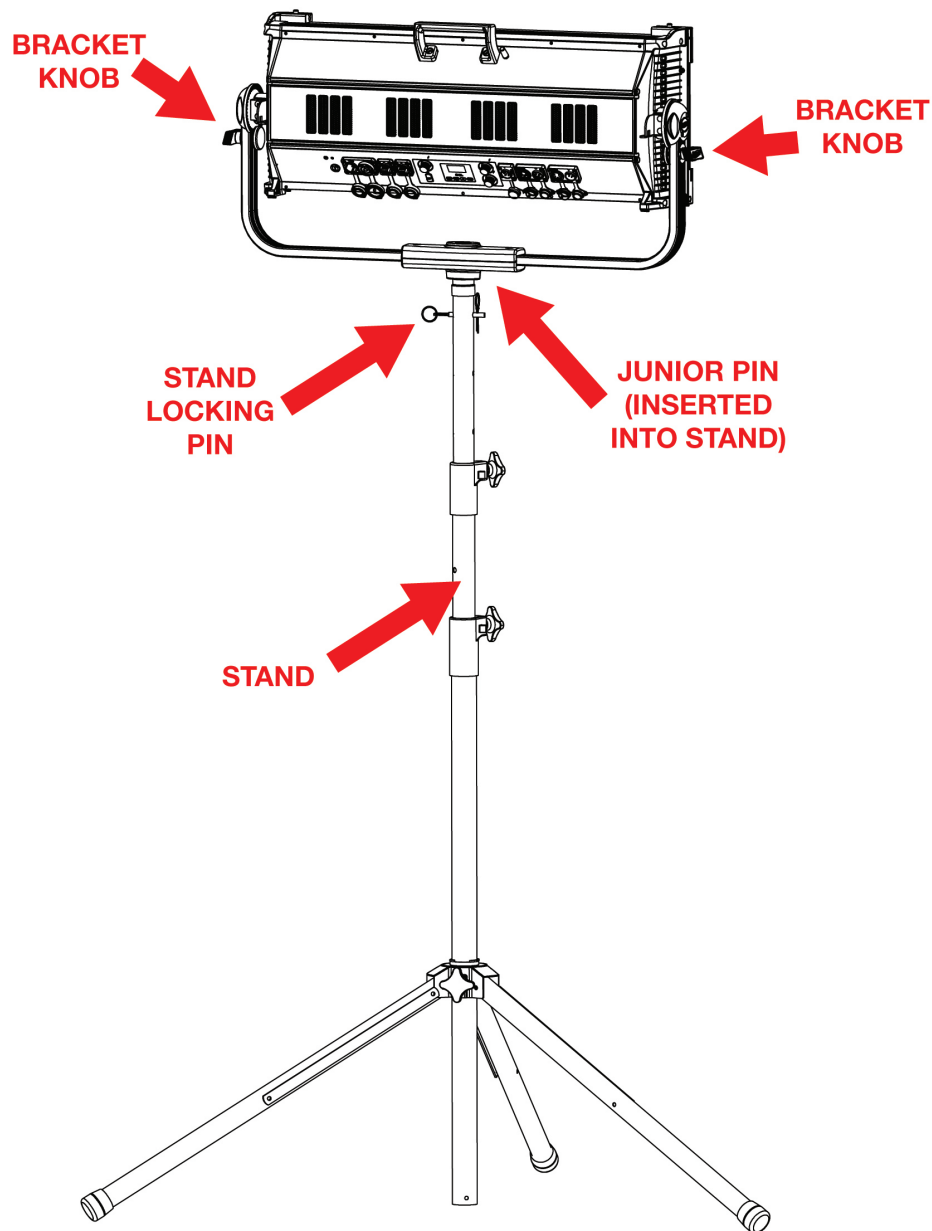

ACCESSORY INSTALLATION

BARN DOOR INSTALLATION

1. Unlock both frame lock tabs using the latches located on each tab (circled in the image below). Flip the top edge of the frame upward.

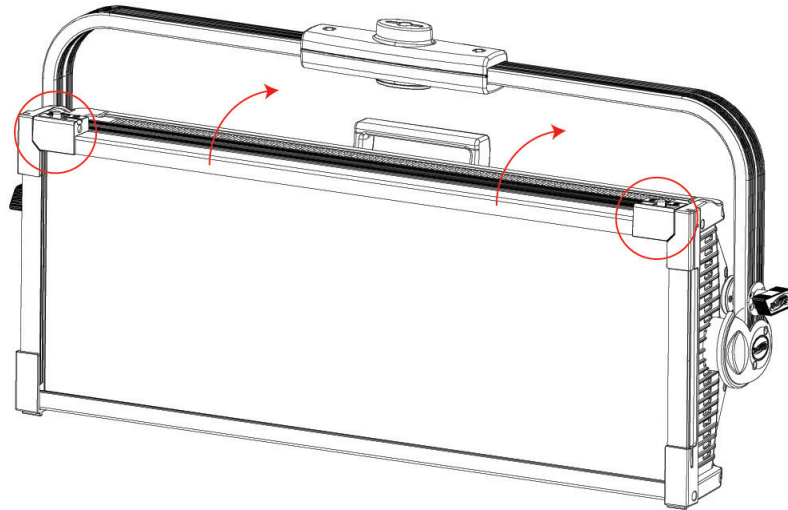

2. Look beneath the frame lock tabs and locate the installation slots on the inner edge of the frame. The slot closest to the front of the device should be vacant. Carefully slide the barndoor into this slot, then flip down the top edge of the frame and lock the frame lock tabs back in place.

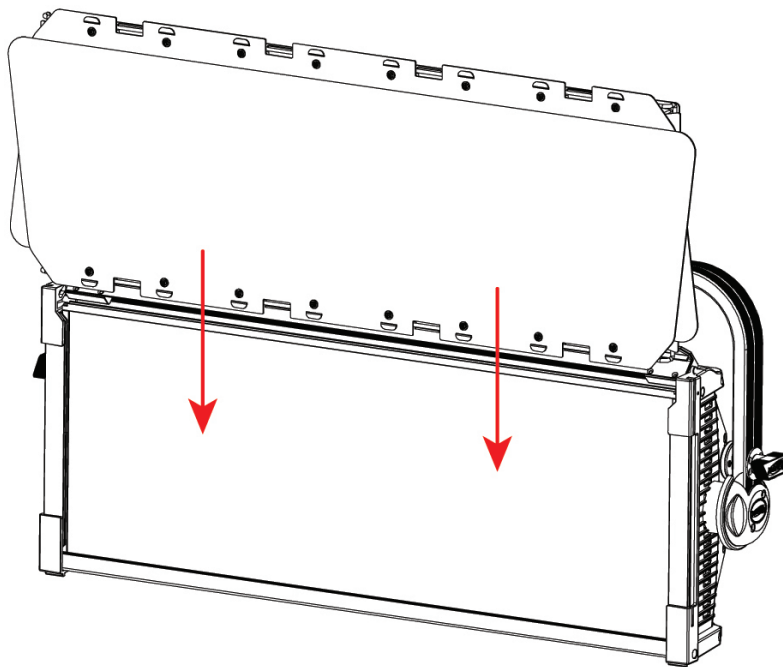

3. With the barndoors locked securely in place, pull on the tabs at the edges of the barndoor flaps to deploy the barndoors. Installation is now complete. **Please note that the barndoor accessory must be installed with its own safety cable! Refer to the diagram in the Fixture Installation section of this manual.**

ACCESSORY INSTALLATION

INTENSIFIER LENS INSTALLATION

1. Unlock both frame lock tabs using the latches located on each tab (circled in the image below). Flip the top edge of the frame upward. Slide the standard lens upward out of its slot.

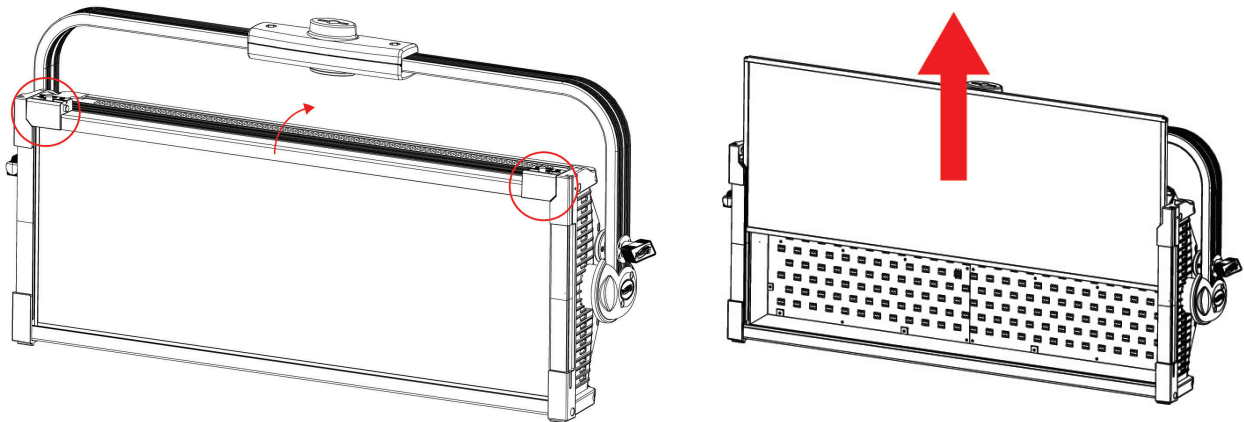

2. Slide the Intensifier Lens into the slot. **Please note that the Intensifier Lens is NOT reversible. The forward-facing side of the Intensifier Lens should have a slight ridge in the lens frame, while the rearward-facing side should have a smooth lens frame.**

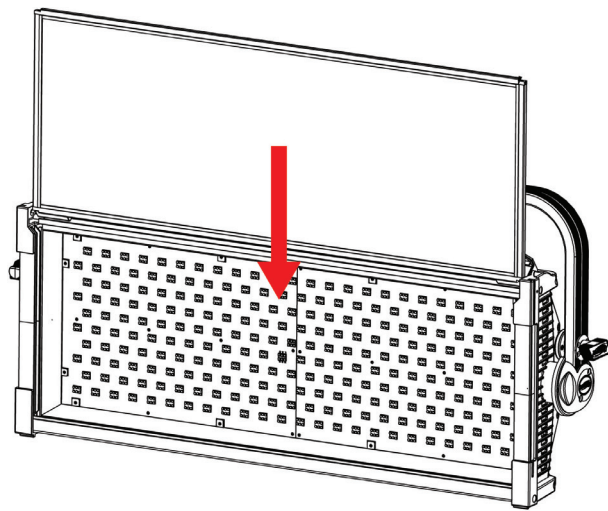

3. Flip the top edge of the fixture frame back down into place, and lock the frame tabs back into place. The installation is now complete.

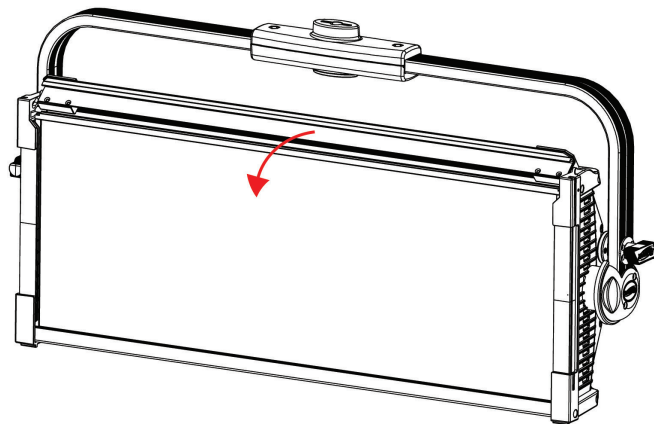

BATTERY CONNECTION

This device is capable of receiving power from a battery pack.

NOTICE: *The user is responsible for ensuring compatibility between the device and the battery pack. Always ensure that the output specifications, operating conditions, and connection pinouts of the battery pack match the device requirements.*

The device features a 4-pin XLR connector for battery power. The connector is located on the back of the device, next to the DMX In/Out connectors, and is covered with a dust cap. **BE CAREFUL NOT TO CONNECT BATTERY POWER TO ONE OF THE DMX CONNECTORS BY MISTAKE!**

The pinout is illustrated below:

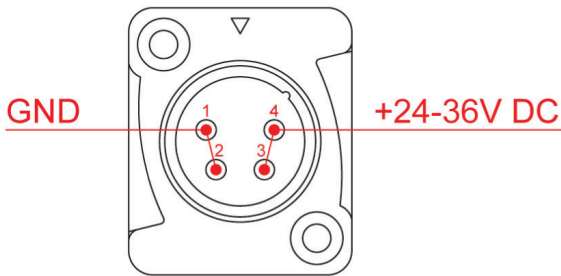

Pin	Assignment
1	GND
2	
3	+24-36V DC
4	

Consult the **Safety Guidelines** section of this user manual, as well as any safety instructions included with your battery pack before use or installation.

The device consumes up to 544W when operating all LEDs at full output, which may require significant battery output to provide the required power. To extend the battery life, it is possible to reduce the LED power by up to 50% of maximum output using the “LED Power Limit” menu in the Personality section of the system menu. Please refer to the **System Menu** section of this manual for detailed information.

SYSTEM MENU

The fixture includes an easy to navigate system menu. The control panel (see image below) located on the back of the fixture provides access to the main system menu, where all necessary system adjustments are made. During normal operation, pressing the MODE button once will access the fixture's main menu. Once in the main menu, you can navigate through the different functions and access the sub-menus with the UP and DOWN buttons. Once you reach a field that requires adjusting, press the ENTER button to activate that field and use the UP and DOWN buttons to adjust the field. Pressing the ENTER button once more will confirm your setting. You may exit the main menu at any time without making any adjustments by pressing the MODE button.

The display screen can be locked by selecting **PERSONALITY > DISPLAY > SCREEN LOCK**. To unlock the display screen, simply press and hold the MODE button for three (3) seconds.

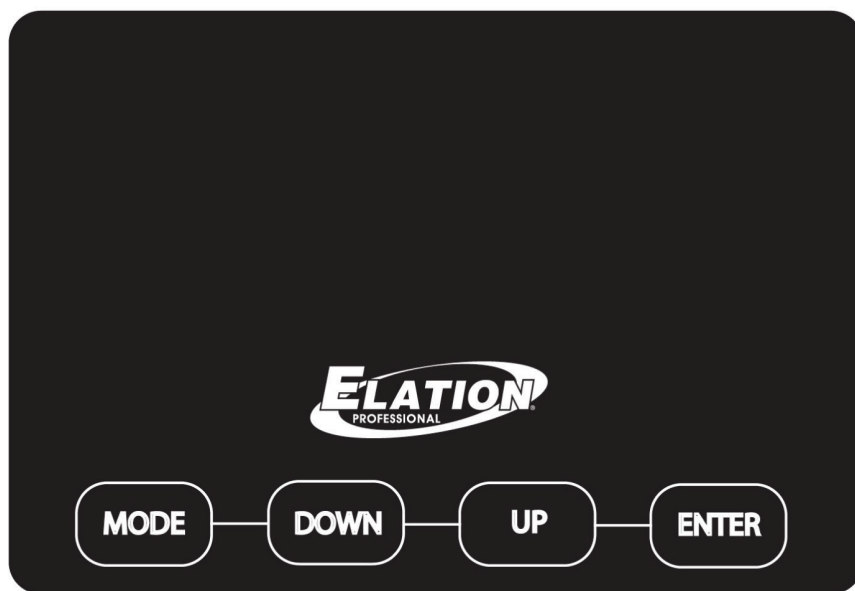

SYSTEM MENU

ELATION KL Panel XL - System Menu				
Supports Software Versions: 1.07				
HOME INTERFACE SHOW	xx CH xxxx ADDR: 001		Displays currently selected DMX mode	
ENCODER MODE	Disabled		Select to run fixture in DMX control mode	
	Int CCT GRN		Select to run fixture in CCT mode with encoder control	
	HSI		Select to run fixture in HSI mode with encoder control	
	Int Color Sat		Select to run fixture in Color mode with encoder control	
	Manual Control		Select to run fixture in manual control mode with encoder control	
DMX SETTINGS	DMX Address	001 - 512		
	DMX Mode	1Ch Dimmer		
		4Ch Dimmer Color		
		7Ch Dimmer Color FX		
		6Ch RGBWLC		
		12Ch RGBWLC 16bit		
		48Ch RGBWLC Cells		
		96Ch RGBWLC Cells 16bit		
		24CH RGB Cells		
		14Ch Standard		
		23Ch Extended		
		58Ch Extended Cells		
	4Ch HSI			
	12Ch HSI Ex			
	No DMX Status	Hold Last		
Fade to Black				
Standalone				
CONTINUED ON NEXT PAGE				

SYSTEM MENU

ELATION KL Panel XL - System Menu				
Supports Software Versions: 1.07				
STANDALONE	Dimmer	0% - 100%		
	CCT	2000K - 10000K		
	Green Shift	-100% - +100%	Default = 0%	
	Virtual Color	Color01 - Color53		
PERSONALITY	Primary	On / Off		
	Secondary	On / Off		
	Select Signal	DMX or E-Fly		
		E-Fly and DMX Out		
	Dim Mode	Standard		
		Stage		
		Architectural		
		Theatre		
		Stage 2		
		Dim Speed	0s - 10s	Default = 0.0 s
	Dim Curves	Linear		
		Square		
		Square Inverse		
		S-Curve		
	E-Fly Setting	E-Fly Setting Set Channel	00 - 14	
		Enable E-Fly	Yes / No	
	LED Refresh Rate	900Hz - 1500Hz, 2500Hz, 4000Hz, 5000Hz, 6000Hz, 10KHz, 15KHz, 20KHz, 25KHz		Default = 1200 Hz
	LED Power Limit	50%		
		60%		
		70%		
80%				
90%				
100%				
Fan Mode	Auto			
	Silent			
	High			
CONTINUED ON NEXT PAGE				

SYSTEM MENU

ELATION KL Panel XL - System Menu					
Supports Software Versions: 1.07					
PERSONALITY (continued)	Display	Display Screen Delay	10s - 5min (default = 1min)	Display returns to home screen after 30s of inactivity	
		Display Screen Lock	Off , 10s - 5min		
		Rotate Display	Yes / No / Auto		
	Network	Switch	On / Off		
		Universe	0 - 255		
		IP: 002.000.000.002			
		Subnet: 255.000.000.000			
		Protocol	ArtNet / KlingNet		
	Service	Passcode = 050	Calibration	Red: 50 - 255	
				Green: 50 - 255	
				Blue: 50 - 255	
				...	
		Update Software (USB Update)	Yes / No		
		Factory Restore	Yes / No		
		Edit RDM UID	xxxxxx		
INFORMATION	Life Time	xxxxxx hrs		Total fixture run time, not resettable	
	Last Run Time	xxxxxx hrs		Fixture run time, resettable	
	Time Reset	Passcode = 038		Reset Last Run Time	
	Temperature	Current			
		Max Resettable			
		Reset (passcode = 038)			
	DMX Values	R: xxx			
		G: xxx			
		B: xxx			
		...			
	Product IDs	Max Address			
		RDM UID			
Error Logs	Fixture Errors				
Reset Error Log	No / Yes	Passcode = 050			
Software Verson	Vx.x.x				

MANUAL MODE

ENCODER KNOB DESIGNATIONS

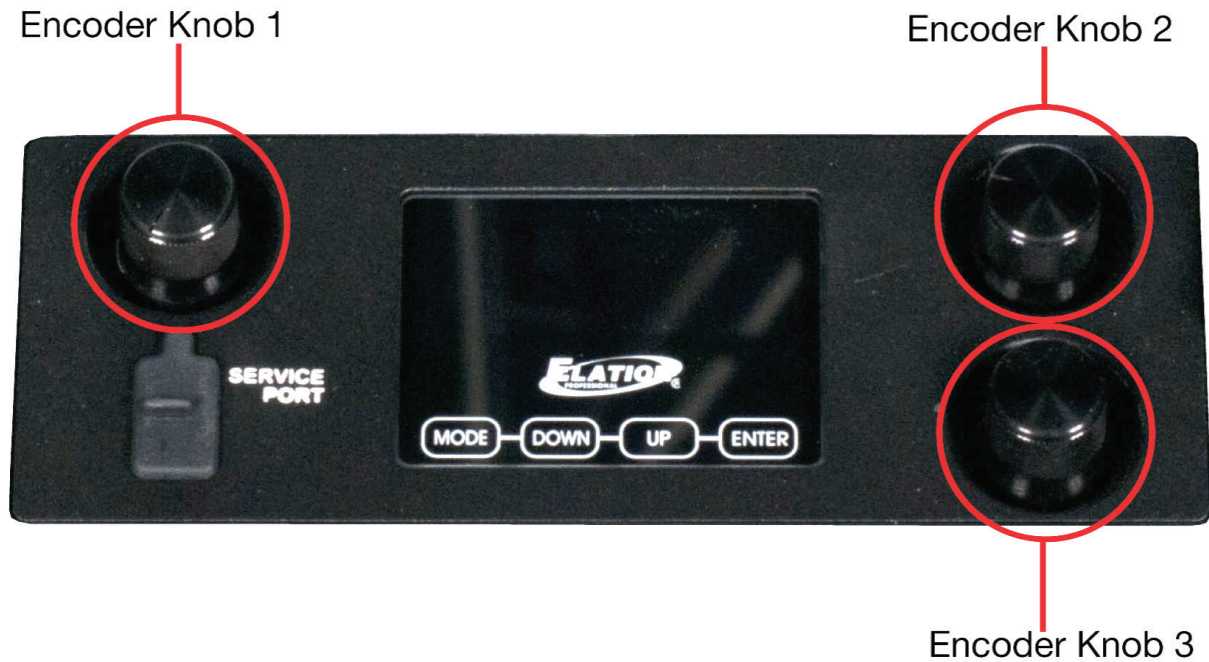

INT CCT GRN (INTENSITY, COLOR TEMPERATURE, GREEN SHIFT)

Encoder Knob	Parameter	Display	Resolution/Steps	Default
1	Intensity	Intensity 0 - 100%	1%	0%
2	Color Temperature	CCT 2000 - 10000K	100K	6000K
3	Green Shift	GRN -100% - +100%	1%	Neutral

HSI (HUE, SATURATION, INTENSITY)

Encoder Knob	Parameter	Display	Resolution/Steps	Default
1	Intensity	Intensity 0 - 100%	1%	0%
2	Hue	Hue 0 - 360°	1°	0°
3	Saturation	Sat 0 - 100%	1%	100%

MANUAL MODE

INT COL SAT (INTENSITY, COLOR, SATURATION)

Encoder Knob	Parameter	Display	Resolution/Steps	Default
1	Intensity	Intensity 0 - 100%	1%	0%
2	Color	White, Virtual Color 1, 2, 3...	Single Color	White
3	Saturation	Sat 0 - 100%	1%	100%

MANUAL

Encoder Knob	Parameter	Display	Resolution/Steps	Default
1	Intensity	Intensity 0 - 100%	1%	0%
2	Setting Adjustment	[Setting Name] 0 - 255	1	0
3	Setting Selection	[Setting Name] 0 - 255	Strobe / Red / Green / Blue / White / Lime / Cyan	Strobe

DMX CHANNEL FUNCTIONS AND VALUES

DIMMER MODE (1 CHANNEL)

Elation KL Panel XL DMX Channels / Functions				
Supports Software Versions: 1.07				
Channel	Value	Function	Default	Snap
1	000 - 255	Dimmer , Intensity 0% to 100%	0	

DIMMER COLOR MODE (4 CHANNELS)

Elation KL Panel XL DMX Channels / Functions				
Supports Software Versions: 1.07				
Channel	Values	Function	Default	Snap
1	000 - 255	Dimmer , Intensity 0% to 100%	0	
2	000 - 255	Dimmer Fine	0	
3		CCT	0	
	000 - 019	Open		
	020 - 100	CCT 2000K - 10000K, see Color Temperature Chart		
	101 - 255	10000K		
4		Color Wheel	0	
	000	Open		
	001 - 179	Virtual Swatch Book, see Virtual Swatch Book Chart		
		Color Scroll		
	180 - 201	Clockwise, fast to slow		
	202 - 207	Stop		
	208 - 229	Counter-clockwise, slow to fast		
	230 - 234	Open		
		Random Slots		
	235 - 239	Fast		
	240 - 244	Medium		
	245 - 249	Slow		
	250 - 255	Open		

DMX CHANNEL FUNCTIONS AND VALUES

DIMMER COLOR FX MODE (7 CHANNELS)

Elation KL Panel XL DMX Channels / Functions				
Supports Software Versions: 1.07				
Channel	Values	Function	Default	Snap
1	000 - 255	Dimmer , Intensity 0% to 100%	0	
2	000 - 255	Dimmer Fine	0	
3		CCT	0	
	000 - 019	Open		
	020 - 100	CCT 2000K - 10000K, see Color Temperature Chart		
	101 - 255	10000K		
4		Color Wheel	0	
	000	Open		
	001 - 179	Virtual Swatch Book, see Virtual Swatch Book Chart		
		Color Scroll		
	180 - 201	Clockwise, fast to slow		
	202 - 207	Stop		
	208 - 229	Counter-clockwise, slow to fast		
	230 - 234	Open		
		Random Slots		
	235 - 239	Fast		
	240 - 244	Medium		
	245 - 249	Slow		
	250 - 255	Open		
5	000 - 255	FX Selection , see FX Table	0	Snap
6	000 - 255	FX Adjustment , see FX Adjustment Table	127	Fade
7		FX Offset	0	Snap
	000	Idle		
	001 - 035	Fixture Offset, 10 degrees to 350 degrees		
	036	Synchronized		
	037 - 100	No Function		
	101 - 120	Random Fixture Offset		
	121 - 140	Random Pixel Order		
141 - 255	Random Steps			

DMX CHANNEL FUNCTIONS AND VALUES

RGBWLC MODE (6 CHANNELS)

Elation KL Panel XL DMX Channels / Functions				
Supports Software Versions: 1.07				
Channel	Values	Function	Default	Snap
1	000 - 255	Red , 0% to 100%	255	
2	000 - 255	Green , 0% to 100%	255	
3	000 - 255	Blue , 0% to 100%	255	
4	000 - 255	White , 0% to 100%	255	
5	000 - 255	Lime , 0% to 100%	255	
6	000 - 255	Cyan , 0% to 100%	255	

RGBWLC 16-BIT MODE (12 CHANNELS)

Elation KL Panel XL DMX Channels / Functions				
Supports Software Versions: 1.07				
Channel	Values	Function	Default	Snap
1	000 - 255	Red , 0% to 100%	255	
2	000 - 255	Red Fine , 0% to 100%	255	
3	000 - 255	Green , 0% to 100%	255	
4	000 - 255	Green Fine , 0% to 100%	255	
5	000 - 255	Blue , 0% to 100%	255	
6	000 - 255	Blue Fine , 0% to 100%	255	
7	000 - 255	White , 0% to 100%	255	
8	000 - 255	White Fine , 0% to 100%	255	
9	000 - 255	Lime , 0% to 100%	255	
10	000 - 255	Lime Fine , 0% to 100%	255	
11	000 - 255	Cyan , 0% to 100%	255	
12	000 - 255	Cyan Fine , 0% to 100%	255	

DMX CHANNEL FUNCTIONS AND VALUES

RGBWLC CELLS MODE (48 CHANNELS)

Elation KL Panel XL DMX Channels / Functions				
Supports Software Versions: 1.07				
Channel	Values	Function	Default	Snap
1	000 - 255	Red1 , 0% to 100%	255	
2	000 - 255	Green1 , 0% to 100%	255	
3	000 - 255	Blue1 , 0% to 100%	255	
4	000 - 255	White1 , 0% to 100%	255	
5	000 - 255	Lime1 , 0% to 100%	255	
6	000 - 255	Cyan1 , 0% to 100%	255	
7	000 - 255	Red2 , 0% to 100%	255	
8	000 - 255	Green2 , 0% to 100%	255	
9	000 - 255	Blue2 , 0% to 100%	255	
10	000 - 255	White2 , 0% to 100%	255	
11	000 - 255	Lime2 , 0% to 100%	255	
12	000 - 255	Cyan2 , 0% to 100%	255	
13	000 - 255	Red3 , 0% to 100%	255	
14	000 - 255	Green3 , 0% to 100%	255	
15	000 - 255	Blue3 , 0% to 100%	255	
16	000 - 255	White3 , 0% to 100%	255	
17	000 - 255	Lime3 , 0% to 100%	255	
18	000 - 255	Cyan3 , 0% to 100%	255	
19	000 - 255	Red4 , 0% to 100%	255	
20	000 - 255	Green4 , 0% to 100%	255	
21	000 - 255	Blue4 , 0% to 100%	255	
22	000 - 255	White4 , 0% to 100%	255	
23	000 - 255	Lime4 , 0% to 100%	255	
24	000 - 255	Cyan4 , 0% to 100%	255	
25	000 - 255	Red5 , 0% to 100%	255	
26	000 - 255	Green5 , 0% to 100%	255	
27	000 - 255	Blue5 , 0% to 100%	255	
28	000 - 255	White5 , 0% to 100%	255	
29	000 - 255	Lime5 , 0% to 100%	255	
30	000 - 255	Cyan5 , 0% to 100%	255	
31	000 - 255	Red6 , 0% to 100%	255	
32	000 - 255	Green6 , 0% to 100%	255	
33	000 - 255	Blue6 , 0% to 100%	255	
34	000 - 255	White6 , 0% to 100%	255	

CONTINUED ON NEXT PAGE

DMX CHANNEL FUNCTIONS AND VALUES

RGBWLC CELLS MODE (48 CHANNELS) *(continued)*

Elation KL Panel XL DMX Channels / Functions				
Supports Software Versions: 1.07				
Channel	Values	Function	Default	Snap
35	000 - 255	Lime6 , 0% to 100%	255	
36	000 - 255	Cyan6 , 0% to 100%	255	
37	000 - 255	Red7 , 0% to 100%	255	
38	000 - 255	Green7 , 0% to 100%	255	
39	000 - 255	Blue7 , 0% to 100%	255	
40	000 - 255	White7 , 0% to 100%	255	
41	000 - 255	Lime7 , 0% to 100%	255	
42	000 - 255	Cyan7 , 0% to 100%	255	
43	000 - 255	Red8 , 0% to 100%	255	
44	000 - 255	Green8 , 0% to 100%	255	
45	000 - 255	Blue8 , 0% to 100%	255	
46	000 - 255	White8 , 0% to 100%	255	
47	000 - 255	Lime8 , 0% to 100%	255	
48	000 - 255	Cyan8 , 0% to 100%	255	

RGBWLC CELLS 16-BIT MODE (96 CHANNELS)

Elation KL Panel XL DMX Channels / Functions				
Supports Software Versions: 1.07				
Channel	Values	Function	Default	Snap
1	000 - 255	Red1 , 0% to 100%	255	
2	000 - 255	Red1 Fine , 0% to 100%	255	
3	000 - 255	Green1 , 0% to 100%	255	
4	000 - 255	Green1 Fine , 0% to 100%	255	
5	000 - 255	Blue1 , 0% to 100%	255	
6	000 - 255	Blue1 Fine , 0% to 100%	255	
7	000 - 255	White1 , 0% to 100%	255	
8	000 - 255	White1 Fine , 0% to 100%	255	
9	000 - 255	Lime1 , 0% to 100%	255	
10	000 - 255	Lime1 Fine , 0% to 100%	255	
11	000 - 255	Cyan1 , 0% to 100%	255	
12	000 - 255	Cyan1 Fine , 0% to 100%	255	
13	000 - 255	Red2 , 0% to 100%	255	
14	000 - 255	Red2 Fine , 0% to 100%	255	
15	000 - 255	Green2 , 0% to 100%	255	

CONTINUED ON NEXT PAGE

DMX CHANNEL FUNCTIONS AND VALUES

RGBWLC CELLS 16-BIT MODE (96 CHANNELS) *(continued)*

Elation KL Panel XL DMX Channels / Functions				
Supports Software Versions: 1.07				
Channel	Values	Function	Default	Snap
16	000 - 255	Green2 Fine , 0% to 100%	255	
17	000 - 255	Blue2 , 0% to 100%	255	
18	000 - 255	Blue2 Fine , 0% to 100%	255	
19	000 - 255	White2 , 0% to 100%	255	
20	000 - 255	White2 Fine , 0% to 100%	255	
21	000 - 255	Lime2 , 0% to 100%	255	
22	000 - 255	Lime2 Fine , 0% to 100%	255	
23	000 - 255	Cyan2 , 0% to 100%	255	
24	000 - 255	Cyan2 Fine , 0% to 100%	255	
25	000 - 255	Red3 , 0% to 100%	255	
26	000 - 255	Red3 Fine , 0% to 100%	255	
27	000 - 255	Green3 , 0% to 100%	255	
28	000 - 255	Green3 Fine , 0% to 100%	255	
29	000 - 255	Blue3 , 0% to 100%	255	
30	000 - 255	Blue3 Fine , 0% to 100%	255	
31	000 - 255	White3 , 0% to 100%	255	
32	000 - 255	White3 Fine , 0% to 100%	255	
33	000 - 255	Lime3 , 0% to 100%	255	
34	000 - 255	Lime3 Fine , 0% to 100%	255	
35	000 - 255	Cyan3 , 0% to 100%	255	
36	000 - 255	Cyan3 Fine , 0% to 100%	255	
37	000 - 255	Red4 , 0% to 100%	255	
38	000 - 255	Red4 Fine , 0% to 100%	255	
39	000 - 255	Green4 , 0% to 100%	255	
40	000 - 255	Green4 Fine , 0% to 100%	255	
41	000 - 255	Blue4 , 0% to 100%	255	
42	000 - 255	Blue4 Fine , 0% to 100%	255	
43	000 - 255	White4 , 0% to 100%	255	
44	000 - 255	White4 Fine , 0% to 100%	255	
45	000 - 255	Lime4 , 0% to 100%	255	
46	000 - 255	Lime4 Fine , 0% to 100%	255	
47	000 - 255	Cyan4 , 0% to 100%	255	
48	000 - 255	Cyan4 Fine , 0% to 100%	255	
49	000 - 255	Red5 , 0% to 100%	255	

CONTINUED ON NEXT PAGE

DMX CHANNEL FUNCTIONS AND VALUES

RGBWLC CELLS 16-BIT MODE (96 CHANNELS) *(continued)*

Elation KL Panel XL DMX Channels / Functions				
Supports Software Versions: 1.07				
Channel	Values	Function	Default	Snap
50	000 - 255	Red5 Fine , 0% to 100%	255	
51	000 - 255	Green5 , 0% to 100%	255	
52	000 - 255	Green5 Fine , 0% to 100%	255	
53	000 - 255	Blue5 , 0% to 100%	255	
54	000 - 255	Blue5 Fine , 0% to 100%	255	
55	000 - 255	White5 , 0% to 100%	255	
56	000 - 255	White5 Fine , 0% to 100%	255	
57	000 - 255	Lime5 , 0% to 100%	255	
58	000 - 255	Lime5 Fine , 0% to 100%	255	
59	000 - 255	Cyan5 , 0% to 100%	255	
60	000 - 255	Cyan5 Fine , 0% to 100%	255	
61	000 - 255	Red6 , 0% to 100%	255	
62	000 - 255	Red6 Fine , 0% to 100%	255	
63	000 - 255	Green6 , 0% to 100%	255	
64	000 - 255	Green6 Fine , 0% to 100%	255	
65	000 - 255	Blue6 , 0% to 100%	255	
66	000 - 255	Blue6 Fine , 0% to 100%	255	
67	000 - 255	White6 , 0% to 100%	255	
68	000 - 255	White6 Fine , 0% to 100%	255	
69	000 - 255	Lime6 , 0% to 100%	255	
70	000 - 255	Lime6 Fine , 0% to 100%	255	
71	000 - 255	Cyan6 , 0% to 100%	255	
72	000 - 255	Cyan6 Fine , 0% to 100%	255	
73	000 - 255	Red7 , 0% to 100%	255	
74	000 - 255	Red7 Fine , 0% to 100%	255	
75	000 - 255	Green7 , 0% to 100%	255	
76	000 - 255	Green7 Fine , 0% to 100%	255	
77	000 - 255	Blue7 , 0% to 100%	255	
78	000 - 255	Blue7 Fine , 0% to 100%	255	
79	000 - 255	White7 , 0% to 100%	255	
80	000 - 255	White7 Fine , 0% to 100%	255	
81	000 - 255	Lime7 , 0% to 100%	255	
82	000 - 255	Lime7 Fine , 0% to 100%	255	
83	000 - 255	Cyan7 , 0% to 100%	255	

CONTINUED ON NEXT PAGE

DMX CHANNEL FUNCTIONS AND VALUES

RGBWLC CELLS 16-BIT MODE (96 CHANNELS) *(continued)*

Elation KL Panel XL DMX Channels / Functions				
Supports Software Versions: 1.07				
Channel	Values	Function	Default	Snap
84	000 - 255	Cyan7 Fine , 0% to 100%	255	
85	000 - 255	Red8 , 0% to 100%	255	
86	000 - 255	Red8 Fine , 0% to 100%	255	
87	000 - 255	Green8 , 0% to 100%	255	
88	000 - 255	Green8 Fine , 0% to 100%	255	
89	000 - 255	Blue8 , 0% to 100%	255	
90	000 - 255	Blue8 Fine , 0% to 100%	255	
91	000 - 255	White8 , 0% to 100%	255	
92	000 - 255	White8 Fine , 0% to 100%	255	
93	000 - 255	Lime8 , 0% to 100%	255	
94	000 - 255	Lime8 Fine , 0% to 100%	255	
95	000 - 255	Cyan8 , 0% to 100%	255	
96	000 - 255	Cyan8 Fine , 0% to 100%	255	

RGB CELLS MODE (24 CHANNELS)

Elation KL Panel XL DMX Channels / Functions				
Supports Software Versions: 1.07				
Channel	Values	Function	Default	Snap
1	000 - 255	Red1 , 0% to 100%	255	
2	000 - 255	Green1 , 0% to 100%	255	
3	000 - 255	Blue1 , 0% to 100%	255	
4	000 - 255	Red2 , 0% to 100%	255	
5	000 - 255	Green2 , 0% to 100%	255	
6	000 - 255	Blue2 , 0% to 100%	255	
7	000 - 255	Red3 , 0% to 100%	255	
8	000 - 255	Green3 , 0% to 100%	255	
9	000 - 255	Blue3 , 0% to 100%	255	
10	000 - 255	Red4 , 0% to 100%	255	
11	000 - 255	Green4 , 0% to 100%	255	
12	000 - 255	Blue4 , 0% to 100%	255	
13	000 - 255	Red5 , 0% to 100%	255	
14	000 - 255	Green5 , 0% to 100%	255	
15	000 - 255	Blue5 , 0% to 100%	255	
16	000 - 255	Red6 , 0% to 100%	255	

CONTINUED ON NEXT PAGE

DMX CHANNEL FUNCTIONS AND VALUES

RGB CELLS MODE (24 CHANNELS) (continued)

Elation KL Panel XL DMX Channels / Functions				
Supports Software Versions: 1.07				
Channel	Values	Function	Default	Snap
17	000 - 255	Green6 , 0% to 100%	255	
18	000 - 255	Blue6 , 0% to 100%	255	
19	000 - 255	Red7 , 0% to 100%	255	
20	000 - 255	Green7 , 0% to 100%	255	
21	000 - 255	Blue7 , 0% to 100%	255	
22	000 - 255	Red8 , 0% to 100%	255	
23	000 - 255	Green8 , 0% to 100%	255	
24	000 - 255	Blue8 , 0% to 100%	255	

STANDARD MODE (14 CHANNELS)

Elation KL Panel XL DMX Channels / Functions				
Supports Software Versions: 1.07				
Channel	Values	Function	Default	Snap
1		Shutter, Strobe	50	Snap
	000 - 031	Shutter closed		
	032 - 063	No function (shutter open)		
	064 - 095	Strobe effect, slow to fast		
	096 - 127	No function (shutter open)		
	128 - 159	Pulse effect in sequences		
	160 - 191	No function (shutter open)		
	192 - 223	Random strobe effect, slow to fast		
	224 - 255	No function (shutter open)		
2	000 - 255	Dimmer , Intensity 0% to 100%	0	
3	000 - 255	Dimmer Fine	0	
4	000 - 255	Red , 0% to 100%	255	
5	000 - 255	Green , 0% to 100%	255	
6	000 - 255	Blue , 0% to 100%	255	
7		CCT	0	
	000 - 019	Open		
	020 - 100	CCT, 2000K to 10000K (see Color Temperature Chart)		
	101 - 255	10000K		

CONTINUED ON NEXT PAGE

DMX CHANNEL FUNCTIONS AND VALUES

STANDARD MODE (14 CHANNELS) *(continued)*

Elation KL Panel XL DMX Channels / Functions				
Supports Software Versions: 1.07				
Channel	Values	Function	Default	Snap
8		Green Shift	0	
	000	Idle		
	001 - 127	Full Minus Green to Neutral		
	128	Neutral White		
	129 - 255	Neutral to Full Plus Green		
9		Color Wheel	0	
	000	Open		
	001 - 179	Virtual Swatch Book, see <i>Virtual Swatch Book Chart</i>		
		Color Scroll		
	180 - 201	Clockwise, fast to slow		
	202 - 207	Stop		
	208 - 229	Counter-clockwise, slow to fast		
	230 - 234	Open		
		Random Slots		
	235 - 239	Fast		
	240 - 244	Medium		
	245 - 249	Slow		
	250 - 255	Open		
10		Dim Modes	0	Snap
	000 - 020	Standard		
	021 - 040	Stage		
	041 - 060	TV		
	061 - 080	Architectural		
	081 - 100	Theatre		
	101 - 120	Stage 2		
		Dimmer Delay Time		
	121	0s		
	122	0.1s		
	123	0.2s		
	124	0.3s		
	125	0.4s		
	126	0.5s		
127	0.6s			
128	0.7s			

CONTINUED ON NEXT PAGE

DMX CHANNEL FUNCTIONS AND VALUES

STANDARD MODE (14 CHANNELS) *(continued)*

Elation KL Panel XL DMX Channels / Functions				
Supports Software Versions: 1.07				
Channel	Values	Function	Default	Snap
10		<i>Dimmer Delay Time (continued)</i>	0	Snap
	129	0.8s		
	130	0.9s		
	131	1.0s		
	132	1.5s		
	133	2.0s		
	134	3.0s		
	135	4.0s		
	136	5.0s		
	137	6.0s		
	138	7.0s		
	139	8.0s		
	140	9.0s		
	141	10s		
	142 - 255	Idle		
11		<i>Control</i>	0	Snap
	000 - 029	Idle		
	030 - 039	Fan Mode Auto		
	040 - 049	Fan Mode Silent		
	050 - 059	Fan Mode High		
	060 - 079	Idle		
	080 - 084	Reset		
	085 - 099	Idle		
	100 - 168	Refresh Rate (Hz), see <i>Refresh Rate Table</i>		
	169 - 200	Idle		
	201 - 210	Dimmer Curve Linear (default)		
	211 - 220	Dimmer Curve Square		
	221 - 230	Dimmer Curve Inverse Square		
	231 - 240	Dimmer Curve S-Curve		
	241	Internal Program 1 (Scene 1-8)		
	242	Internal Program 2 (Scene 9-16)		
	243	Internal Program 3 (Scene 17-24)		
	244	Internal Program 4 (Scene 25-32)		
245	Internal Program 5 (Scene 33-40)			

CONTINUED ON NEXT PAGE

DMX CHANNEL FUNCTIONS AND VALUES

STANDARD MODE (14 CHANNELS) (continued)

Elation KL Panel XL DMX Channels / Functions				
Supports Software Versions: 1.07				
Channel	Values	Function	Default	Snap
11		Control (continued)	0	Snap
	246	Internal Program 6 (Scene 41-48)		
	247	Internal Program 7 (Scene 49-56)		
	248 - 255	Idle		
12	000 - 255	FX Selection, see FX Table	0	Snap
13	000 - 255	FX Adjustment, see FX Adjustment Table	127	Fade
14		FX Offset	0	Snap
	000	Idle		
	001 - 035	Fixture Offset, 10 Degrees to 350 Degrees		
	036	Synchronized		
	037 - 100	No function		
	101 - 120	Random fixture offset		
	121 - 140	Random pixel order		
	141 - 255	Random steps		

EXTENDED MODE (23 CHANNELS)

Elation KL Panel XL DMX Channels / Functions				
Supports Software Versions: 1.07				
Channel	Values	Function	Default	Snap
1		Shutter, Strobe	50	Snap
	000 - 031	Shutter closed		
	032 - 063	No function (shutter open)		
	064 - 095	Strobe effect, slow to fast		
	096 - 127	No function (shutter open)		
	128 - 159	Pulse effect in sequences		
	160 - 191	No function (shutter open)		
	192 - 223	Random strobe effect, slow to fast		
	224 - 255	No function (shutter open)		
2	000 - 255	Dimmer , Intensity 0% to 100%	0	
3	000 - 255	Dimmer Fine	0	
4	000 - 255	Red , 0% to 100%	255	
5	000 - 255	Red Fine , 0% to 100%	255	
6	000 - 255	Green , 0% to 100%	255	
7	000 - 255	Green Fine , 0% to 100%	255	

CONTINUED ON NEXT PAGE

DMX CHANNEL FUNCTIONS AND VALUES

EXTENDED MODE (23 CHANNELS) *(continued)*

Elation KL Panel XL DMX Channels / Functions				
Supports Software Versions: 1.07				
Channel	Values	Function	Default	Snap
8	000 - 255	Blue , 0% to 100%	255	
9	000 - 255	Blue Fine , 0% to 100%	255	
10	000 - 255	White , 0% to 100%	255	
11	000 - 255	White Fine , 0% to 100%	255	
12	000 - 255	Lime , 0% to 100%	255	
13	000 - 255	Lime Fine , 0% to 100%	255	
14	000 - 255	Cyan , 0% to 100%	255	
15	000 - 255	Cyan Fine , 0% to 100%	255	
16		CCT	0	
	000 - 019	Idle		
	020 - 100	CCT, 2000K to 10000K (see Color Temperature Chart)		
	101 - 255	10000K		
17		Green Shift	0	
	000	Idle		
	001 - 127	Full Minus Green to Neutral		
	128	Neutral White		
18		Color Wheel	0	
	000	Open		
	001 - 179	Virtual Swatch Book, see Virtual Swatch Book Chart		
		Color Scroll		
	180 - 201	Clockwise, fast to slow		
	202 - 207	Stop		
	208 - 229	Counter-clockwise, slow to fast		
	230 - 234	Open		
		Random Slots		
	235 - 239	Fast		
	240 - 244	Medium		
	245 - 249	Slow		
250 - 255	Open			

CONTINUED ON NEXT PAGE

DMX CHANNEL FUNCTIONS AND VALUES

EXTENDED MODE (23 CHANNELS) *(continued)*

Elation KL Panel XL DMX Channels / Functions				
Supports Software Versions: 1.07				
Channel	Values	Function	Default	Snap
19		<i>Dim Modes</i>	0	Snap
	000 - 020	Standard		
	021 - 040	Stage		
	041 - 060	TV		
	061 - 080	Architectural		
	081 - 100	Theatre		
	101 - 120	Stage 2		
		<i>Dimmer Delay Time</i>		
	121	0s		
	122	0.1s		
	123	0.2s		
	124	0.3s		
	125	0.4s		
	126	0.5s		
	127	0.6s		
	128	0.7s		
	129	0.8s		
	130	0.9s		
	131	1.0s		
	132	1.5s		
	133	2.0s		
	134	3.0s		
	135	4.0s		
	136	5.0s		
	137	6.0s		
	138	7.0s		
139	8.0s			
140	9.0s			
141	10s			
142 - 255	Idle			
20		<i>Control</i>	0	Snap
	000 - 029	Idle		
	030 - 039	Fan Mode Auto		
	040 - 049	Fan Mode Silent		

CONTINUED ON NEXT PAGE

DMX CHANNEL FUNCTIONS AND VALUES

EXTENDED MODE (23 CHANNELS) *(continued)*

Elation KL Panel XL DMX Channels / Functions				
Supports Software Versions: 1.07				
Channel	Values	Function	Default	Snap
20		Control <i>(continued)</i>	0	Snap
	050 - 059	Fan Mode High		
	060 - 079	Idle		
	080 - 084	Reset		
	085 - 099	Idle		
	100 - 168	Refresh Rate (Hz), see Refresh Rate Table		
	169 - 200	Idle		
	201 - 210	Dimmer Curve Linear (default)		
	211 - 220	Dimmer Curve Square		
	221 - 230	Dimmer Curve Inverse Square		
	231 - 240	Dimmer Curve S-Curve		
	241	Internal Program 1 (Scene 1-8)		
	242	Internal Program 2 (Scene 9-16)		
	243	Internal Program 3 (Scene 17-24)		
	244	Internal Program 4 (Scene 25-32)		
	245	Internal Program 5 (Scene 33-40)		
	246	Internal Program 6 (Scene 41-48)		
	247	Internal Program 7 (Scene 49-56)		
248 - 255	Idle			
21	000 - 255	FX Selection , see FX Table	0	Snap
22	000 - 255	FX Adjustment , see FX Adjustment Table	127	Fade
23		FX Offset	0	Snap
	000	Idle		
	001 - 035	Fixture Offset, 10 Degrees to 350 Degrees		
	036	Synchronized		
	037 - 100	No function		
	101 - 120	Random Fixture Offset		
	121 - 140	Random Pixel Order		
	141 - 255	Random Steps		

DMX CHANNEL FUNCTIONS AND VALUES

EXTENDED CELLS MODE (58 CHANNELS)

Elation KL Panel XL DMX Channels / Functions				
Supports Software Versions: 1.07				
Channel	Values	Function	Default	Snap
1		Shutter, Strobe	50	Snap
	000 - 031	Shutter closed		
	032 - 063	No function (shutter open)		
	064 - 095	Strobe effect, slow to fast		
	096 - 127	No function (shutter open)		
	128 - 159	Pulse effect in sequences		
	160 - 191	No function (shutter open)		
	192 - 223	Random strobe effect, slow to fast		
	224 - 255	No function (shutter open)		
2	000 - 255	Dimmer Intensity , 0% to 100%	0	
3		CCT	0	
	000 - 019	Open		
	020 - 100	CCT, 2000K to 10000K (see Color Temperature Chart)		
	101 - 255	10000K		
4		Green Shift	0	
	000	Idle		
	001 - 127	Full Minus Green to Neutral		
	128	Neutral White		
	129 - 255	Neutral to Full Plus Green		
5		Color Wheel	0	
	000	Open		
	001 - 179	Virtual Swatch Book, see Virtual Swatch Book Table		
		Color Scroll		
	180 - 201	Clockwise, fast to slow		
	202 - 207	Stop		
	208 - 229	Counter-clockwise, slow to fast		
	230 - 234	Open		
		Random Slots		
	235 - 239	Fast		
	240 - 244	Medium		
	245 - 249	Slow		
	250 - 255	Open		
CONTINUED ON NEXT PAGE				

DMX CHANNEL FUNCTIONS AND VALUES

EXTENDED CELLS MODE (58 CHANNELS) *(continued)*

Elation KL Panel XL DMX Channels / Functions				
Supports Software Versions: 1.07				
Channel	Values	Function	Default	Snap
6		<i>Dim Modes</i>	0	Snap
	000 - 020	Standard		
	021 - 040	Stage		
	041 - 060	TV		
	061 - 080	Architectural		
	081 - 100	Theatre		
	101 - 120	Stage 2		
		<i>Dimmer Delay Time</i>		
	121	0s		
	122	0.1s		
	123	0.2s		
	124	0.3s		
	125	0.4s		
	126	0.5s		
	127	0.6s		
	128	0.7s		
	129	0.8s		
	130	0.9s		
	131	1.0s		
	132	1.5s		
	133	2.0s		
	134	3.0s		
	135	4.0s		
	136	5.0s		
	137	6.0s		
	138	7.0s		
139	8.0s			
140	9.0s			
141	10s			
142 - 255	Idle			
7		<i>Control</i>	0	Snap
	000 - 029	Idle		
	030 - 039	Fan Mode Auto		
	040 - 049	Fan Mode Silent		

CONTINUED ON NEXT PAGE

DMX CHANNEL FUNCTIONS AND VALUES

EXTENDED CELLS MODE (58 CHANNELS) *(continued)*

Elation KL Panel XL DMX Channels / Functions				
Supports Software Versions: 1.07				
Channel	Values	Function	Default	Snap
7		Control <i>(continued)</i>	0	Snap
	050 - 059	Fan Mode High		
	060 - 079	Idle		
	080 - 084	Reset		
	085 - 099	Idle		
	100 - 168	Refresh Rate (Hz), see Refresh Rate Table		
	169 - 200	Idle		
	201 - 210	Dimmer Curve Linear (default)		
	211 - 220	Dimmer Curve Square		
	221 - 230	Dimmer Curve Inverse Square		
	231 - 240	Dimmer Curve S-Curve		
	241	Internal Program 1 (Scene 1-8)		
	242	Internal Program 2 (Scene 9-16)		
	243	Internal Program 3 (Scene 17-24)		
	244	Internal Program 4 (Scene 25-32)		
	245	Internal Program 5 (Scene 33-40)		
	246	Internal Program 6 (Scene 41-48)		
247	Internal Program 7 (Scene 49-56)			
248 - 255	Idle			
8	000 - 255	FX Selection , see FX Table	0	Snap
9	000 - 255	FX Adjustment , see FX Adjustment Table	127	Fade
10		FX Offset	0	Snap
	000	Idle		
	001 - 035	Fixture Offset, 10 Degrees to 350 Degrees		
	036	Synchronized		
	037 - 100	No function		
	101 - 120	Random Fixture Offset		
	121 - 140	Random Pixel Order		
141 - 255	Random Steps			
11	000 - 255	Red1 , 0% to 100%	255	
12	000 - 255	Green1 , 0% to 100%	255	
13	000 - 255	Blue1 , 0% to 100%	255	
14	000 - 255	White1 , 0% to 100%	255	
15	000 - 255	Lime1 , 0% to 100%	255	

CONTINUED ON NEXT PAGE

DMX CHANNEL FUNCTIONS AND VALUES

EXTENDED CELLS MODE (58 CHANNELS) *(continued)*

Elation KL Panel XL DMX Channels / Functions				
Supports Software Versions: 1.07				
Channel	Values	Function	Default	Snap
16	000 - 255	Cyan1 , 0% to 100%	255	
17	000 - 255	Red2 , 0% to 100%	255	
18	000 - 255	Green2 , 0% to 100%	255	
19	000 - 255	Blue2 , 0% to 100%	255	
20	000 - 255	White2 , 0% to 100%	255	
21	000 - 255	Lime2 , 0% to 100%	255	
22	000 - 255	Cyan2 , 0% to 100%	255	
23	000 - 255	Red3 , 0% to 100%	255	
24	000 - 255	Green3 , 0% to 100%	255	
25	000 - 255	Blue3 , 0% to 100%	255	
26	000 - 255	White3 , 0% to 100%	255	
27	000 - 255	Lime3 , 0% to 100%	255	
28	000 - 255	Cyan3 , 0% to 100%	255	
29	000 - 255	Red4 , 0% to 100%	255	
30	000 - 255	Green4 , 0% to 100%	255	
31	000 - 255	Blue4 , 0% to 100%	255	
32	000 - 255	White4 , 0% to 100%	255	
33	000 - 255	Lime4 , 0% to 100%	255	
34	000 - 255	Cyan4 , 0% to 100%	255	
35	000 - 255	Red5 , 0% to 100%	255	
36	000 - 255	Green5 , 0% to 100%	255	
37	000 - 255	Blue5 , 0% to 100%	255	
38	000 - 255	White5 , 0% to 100%	255	
39	000 - 255	Lime5 , 0% to 100%	255	
40	000 - 255	Cyan5 , 0% to 100%	255	
41	000 - 255	Red6 , 0% to 100%	255	
42	000 - 255	Green6 , 0% to 100%	255	
43	000 - 255	Blue6 , 0% to 100%	255	
44	000 - 255	White6 , 0% to 100%	255	
45	000 - 255	Lime6 , 0% to 100%	255	
46	000 - 255	Cyan6 , 0% to 100%	255	
47	000 - 255	Red7 , 0% to 100%	255	
48	000 - 255	Green7 , 0% to 100%	255	
49	000 - 255	Blue7 , 0% to 100%	255	

CONTINUED ON NEXT PAGE

DMX CHANNEL FUNCTIONS AND VALUES

EXTENDED CELLS MODE (58 CHANNELS) *(continued)*

Elation KL Panel XL DMX Channels / Functions				
Supports Software Versions: 1.07				
Channel	Values	Function	Default	Snap
50	000 - 255	White7 , 0% to 100%	255	
51	000 - 255	Lime7 , 0% to 100%	255	
52	000 - 255	Cyan7 , 0% to 100%	255	
53	000 - 255	Red8 , 0% to 100%	255	
54	000 - 255	Green8 , 0% to 100%	255	
55	000 - 255	Blue8 , 0% to 100%	255	
56	000 - 255	White8 , 0% to 100%	255	
57	000 - 255	Lime8 , 0% to 100%	255	
58	000 - 255	Cyan8 , 0% to 100%	255	

HSI MODE (4 CHANNELS)

Elation KL Panel XL DMX Channels / Functions				
Supports Software Versions: 1.07				
Channel	Values	Function	Default	Snap
1	000 - 255	Dimmer Intensity , 0% to 100%	0	
2	000 - 255	Dimmer Fine	0	
3	000 - 255	Hue , 0% to 100%	255	
4	000 - 255	Saturation , 0% to 100%	255	

HSI EXTENDED MODE (12 CHANNELS)

Elation KL Panel XL DMX Channels / Functions				
Supports Software Versions: 1.07				
Channel	Values	Function	Default	Snap
1		Shutter, strobe	50	Snap
	000 - 031	Shutter closed		
	032 - 063	No function (shutter open)		
	064 - 095	Strobe effect, slow to fast		
	096 - 127	No function (shutter open)		
	128 - 159	Pulse effect in sequences		
	160 - 191	No function (shutter open)		
	192 - 223	Random strobe effect, slow to fast		
	224 - 255	No function (shutter open)		
2	000 - 255	Dimmer Intensity , 0% to 100%	0	
3	000 - 255	Dimmer Fine	0	

CONTINUED ON NEXT PAGE

DMX CHANNEL FUNCTIONS AND VALUES

HSI EXTENDED MODE (12 CHANNELS) *(continued)*

Elation KL Panel XL DMX Channels / Functions				
Supports Software Versions: 1.07				
Channel	Values	Function	Default	Snap
4	000 - 255	Hue , 0% to 100%	255	
5	000 - 255	Saturation , 0% to 100%	255	
6		CCT	0	
	000 - 019	Open		
	020 - 100	CCT 2000K - 10000K (see Color Temperature Table)		
	101 - 255	10000K		
7		Color Wheel	0	
	000	Open		
	001 - 179	Virtual Swatch Book (see Virtual Swatch Book)		
		Color Scroll		
	180 - 201	Clockwise, fast to slow		
	202 - 207	Stop		
	208 - 229	Counter-clockwise, slow to fast		
	230 - 234	Open		
		Random Slots		
	235 - 239	Fast		
	240 - 244	Medium		
	245 - 249	Slow		
	250 - 255	Open		
8		Dim Modes	0	Snap
	000 - 020	Standard		
	021 - 040	Stage		
	041 - 060	TV		
	061 - 080	Architectural		
	081 - 100	Theatre		
	101 - 120	Stage 2		
		Dimmer Delay Time		
	121	0s		
	122	0.1s		
	123	0.2s		
	124	0.3s		
	125	0.4s		
	126	0.5s		
127	0.6s			

CONTINUED ON NEXT PAGE

DMX CHANNEL FUNCTIONS AND VALUES

HSI EXTENDED MODE (12 CHANNELS) *(continued)*

Elation KL Panel XL DMX Channels / Functions				
Supports Software Versions: 1.07				
Channel	Values	Function	Default	Snap
8		<i>Dimmer Delay Time (continued)</i>	0	Snap
	128	0.7s		
	129	0.8s		
	130	0.9s		
	131	1.0s		
	132	1.5s		
	133	2.0s		
	134	3.0s		
	135	4.0s		
	136	5.0s		
	137	6.0s		
	138	7.0s		
	139	8.0s		
	140	9.0s		
	141	10s		
	142 - 255	Idle		
9		<i>Control</i>	0	Snap
	000 - 029	Idle		
	030 - 039	Fan Mode Auto		
	040 - 049	Fan Mode Silent		
	050 - 059	Fan Mode High		
	060 - 079	Idle		
	080 - 084	Reset		
	085 - 099	Idle		
	100 - 168	Refresh Rate (see <i>Refresh Rate Table</i>)		
	169 - 200	Idle		
	201 - 210	Dimmer Curve Linear (default)		
	211 - 220	Dimmer Curve Square		
	221 - 230	Dimmer Curve Inverse Square		
	231 - 240	Dimmer Curve S-Curve		
	241	Internal Program 1 (Scene 1-8)		
	242	Internal Program 2 (Scene 9-16)		
	243	Internal Program 3 (Scene 17-24)		
244	Internal Program 4 (Scene 25-32)			

CONTINUED ON NEXT PAGE

DMX CHANNEL FUNCTIONS AND VALUES

HSI EXTENDED MODE (12 CHANNELS) *(continued)*

Elation KL Panel XL DMX Channels / Functions				
Supports Software Versions: 1.07				
Channel	Values	Function	Default	Snap
9		Control <i>(continued)</i>	0	Snap
	245	Internal Program 5 (Scene 33-40)		
	246	Internal Program 6 (Scene 41-48)		
	247	Internal Program 7 (Scene 49-56)		
	248 - 255	Idle		
10	000 - 255	FX Selection (see FX Table)	0	Snap
11	000 - 255	FX Adjustment , minimum to maximum (see FX Adjustment Table)	127	Fade
12		FX Offset	0	Snap
	000	Idle		
	001 - 035	Fixture Offset, 0 degrees to 350 degrees		
	036	Synchronized		
	037 - 100	No function		
	101 - 120	Random fixture offset		
	121 - 140	Random pixel order		
	141 - 255	Random steps		

COLOR TEMPERATURE TABLE

Value	Color Temperature	Value	Color Temperature
20	2000	61	6100
21	2100	62	6200
22	2200	63	6300
23	2300	64	6400
24	2400	65	6500
25	2500	66	6600
26	2600	67	6700
27	2700	68	6800
28	2800	69	6900
29	2900	70	7000
30	3000	71	7100
31	3100	72	7200
32	3200	73	7300
33	3300	74	7400
34	3400	75	7500
35	3500	76	7600
36	3600	77	7700
37	3700	78	7800
38	3800	79	7900
39	3900	80	8000
40	4000	81	8100
41	4100	82	8200
42	4200	83	8300
43	4300	84	8400
44	4400	85	8500
45	4500	86	8600
46	4600	87	8700
47	4700	88	8800
48	4800	89	8900
49	4900	90	9000
50	5000	91	9100
51	5100	92	9200
52	5200	93	9300
53	5300	94	9400
54	5400	95	9500
55	5500	96	9600
56	5600	97	9700
57	5700	98	9800
58	5800	99	9900
59	5900	100	10000
60	6000		

VIRTUAL SWATCH BOOK

Value	Filter Number	Name	Value	Filter Number	Name
1	7	Pale Yellow	28	113	Magenta
2	103	Straw	29	46	Dark Magenta
3	151	Gold Tint	30	48	Rose Purple
4	100	Spring Yellow	31	126	Mauve
5	10	Medium Yellow	32	49	Medium Purple
6	101	Yellow	33	58	Lavender
7	104	Deep Amber	34	199	Palace Blue
8	15	Deep Straw	35	119	Dark Blue
9	179	Loving Amber	36	132	Medium Blue
10	21	Gold Amber	37	120	Deep Blue
11	105	Orange	38	165	Daylight Blue
12	158	Deep Orange	39	161	Slate Blue
13	22	Dark Amber	40	118	Light Blue
14	778	Millenium Gold	41	68	Sky Blue
15	135	Deep Golden Amber	42	143	Pale Navy Blue
16	24	Scarlet	43	131	Marine Blue
17	106	Primary Red	44	115	Peacock Blue
18	26	Bright Red	45	172	Lagoon Blue
19	27	Medium Red	46	116	Medium Blue Green
20	19	Fire	47	90	Dark Yellow Green
21	157	Pink	48	139	Primary Green
22	36	Medium Pink	49	122	Fern Green
23	111	Dark Pink	50	89	Moss Green
24	128	Bright Pink	51	124	Dark Green
25	148	Bright Rose	52	88	Lime Green
26	332	Special Rose Pink	53	138	Pale Green
27	793	Vanity Fair	54-179		Not in Use

REFRESH RATE TABLE

DMX Values	Refresh Rate (Hz)	DMX Values	Refresh Rate (Hz)
100	900	135	1250
101	910	136	1260
102	920	137	1270
103	930	138	1280
104	940	139	1290
105	950	140	1300
106	960	141	1310
107	970	142	1320
108	980	143	1330
109	990	144	1340
110	1000	145	1350
111	1010	146	1360
112	1020	147	1370
113	1030	148	1380
114	1040	149	1390
115	1050	150	1400
116	1060	151	1410
117	1070	152	1420
118	1080	153	1430
119	1090	154	1440
120	1100	155	1450
121	1110	156	1460
122	1120	157	1470
123	1130	158	1480
124	1140	159	1490
125	1150	160	1500
126	1160	161	2500
127	1170	162	4000
128	1180	163	5000
129	1190	164	6000
130	1200	165	10000
131	1210	166	15000
132	1220	167	20000
133	1230	168	25000
134	1240		

DIMMER MODES

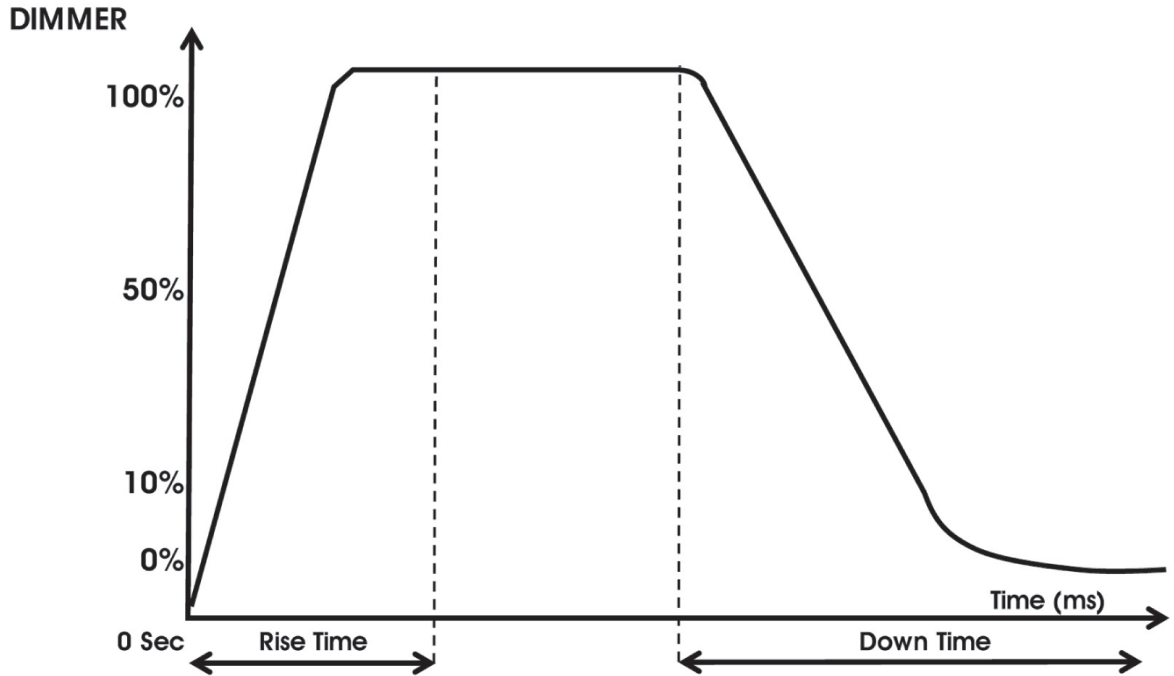

Dimming Curve Ramp Effect	0 sec Fade Time		1 sec Fade Time	
	Rise Time (ms)	Down Time (ms)	Rise Time (ms)	Down Time (ms)
Standard (default)	0	0	0	0
Stage	780	1100	1540	1660
TV	1180	1520	1860	1940
Architectural	1380	1730	2040	2120
Theatre	1580	1940	2230	2280
Stage 2	0	1100	0	1660

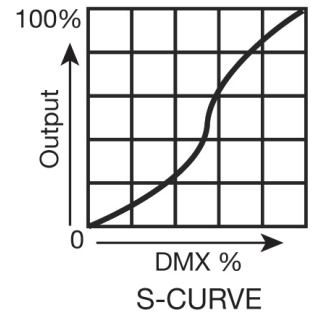
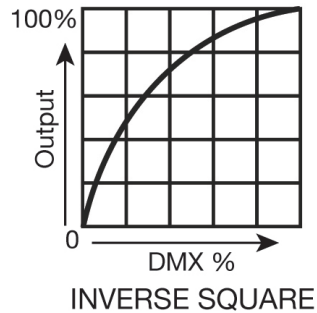
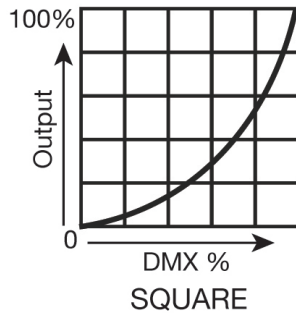
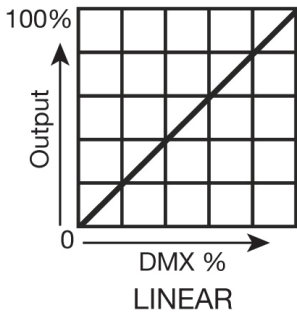

PIXEL ZONES

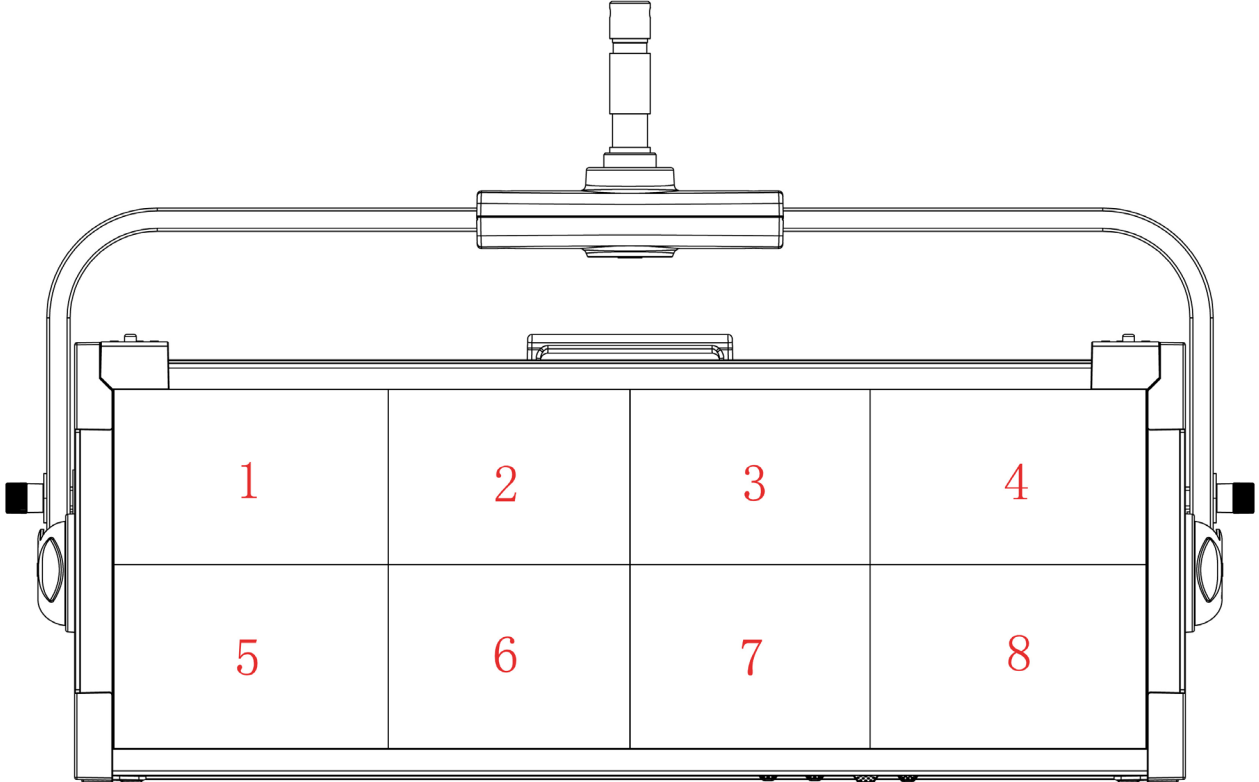

SPECIFICATIONS

SOURCE

6-in-1 (Red, Green, Blue, White, Lime, Cyan) Full Spectrum LED Array
50,000 Hour Average LED Life*

*Test lab conditions. May vary depending on several factors including but not limited to:
Environmental Conditions, Power/Voltage, Usage Patterns (On-Off Cycling), Control, and Dimming.

PHOTOMETRIC DATA

up to 44,000 Total Lumen Output

Diffuser

Beam Angle 101°

Field Angle 159.4°

Without Diffuser

Beam Angle 111°

Field Angle 155.4°

EFFECTS

Variable CCT 2,000K - 10,000K

Green-Shift Adjustment

4x2 Section Control

Virtual Gel Library

Variable 16-bit Dimming Curve Modes

High Speed Electronic Shutter and Strobe

Remote Adjustable LED Refresh Rate Frequency

(900-25kHz)

CONTROL / CONNECTIONS

12 DMX Channel Modes (1-96 Ch.)

1 or 8 cell control sections

3 Manual Adjustment Encoders

4 Button Control Panel and OLED Menu Display

DMX, RDM, Art-NET, sACN Protocol Support

E-FLY™ Internal Extended Range Wireless DMX Transceiver

Locking 5pin XLR Connector In/Out

Locking 3pin XLR Connector In/Out

Locking IP65 Power Connector In/Out

USB Connection (Firmware Updates, External 5V power for accessories)

4pin XLR External Battery Connection (battery not included)

SIZE / WEIGHT

Length: 33.8" (858.0mm)

Width: 6.1" (155.5mm)

Height: 12.1" (306.3mm)

Height (with yoke): 16.8" (426.8mm)

Weight: 37.9 lbs. (17.2 kg)

Weight: (Junior Pin) 1.02 lbs. (0.46 kg)

ELECTRICAL / THERMAL

AC 100-240V - 50/60Hz

24-36 VDC (battery operation - battery not included)

Max Power Consumption 544W

14°F to 113°F (-10°C to 45°C)

APPROVALS / RATINGS

CE | cETLus | IP20

Specifications and documentation are subject to change without prior written notice.

DIMENSIONAL DRAWINGS

FIXTURE ONLY

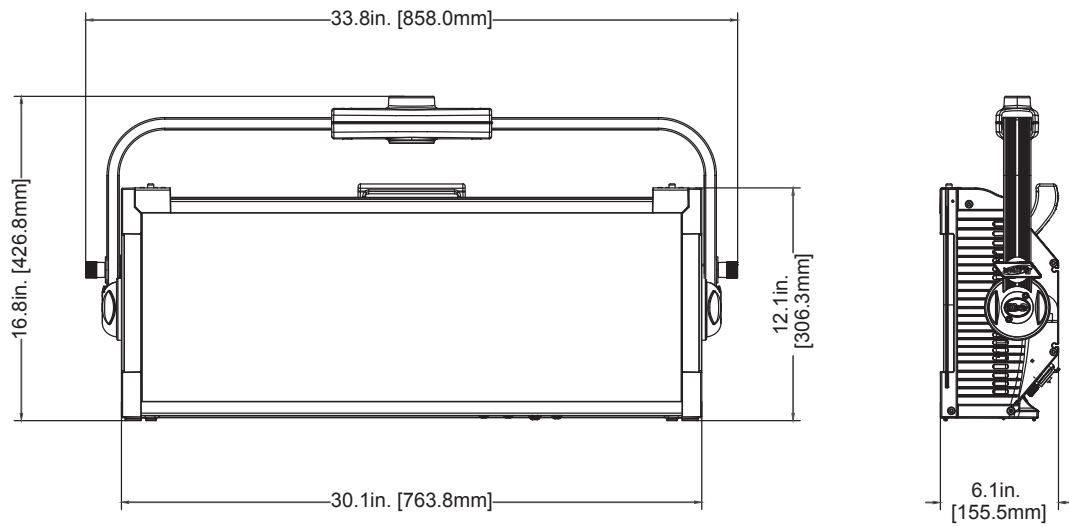

BARNDOOR INSTALLED

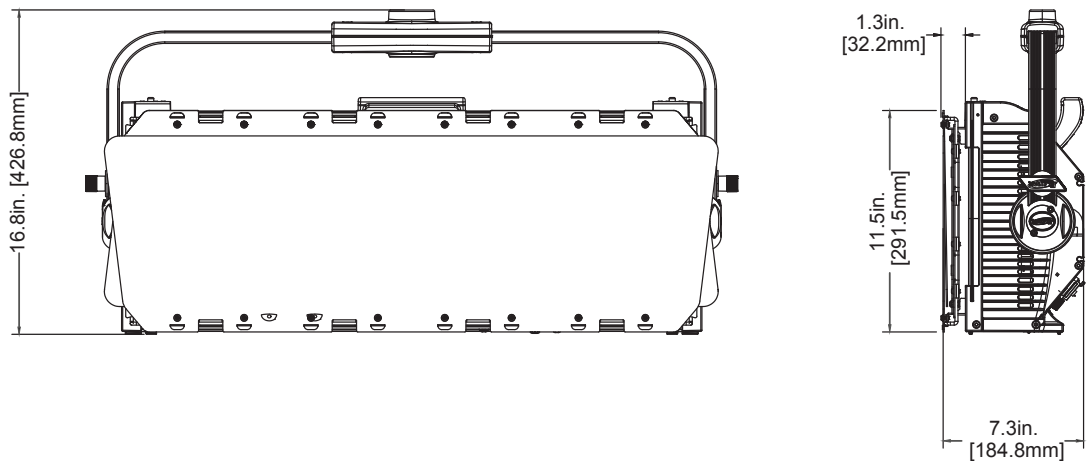

JUNIOR PIN INSTALLED

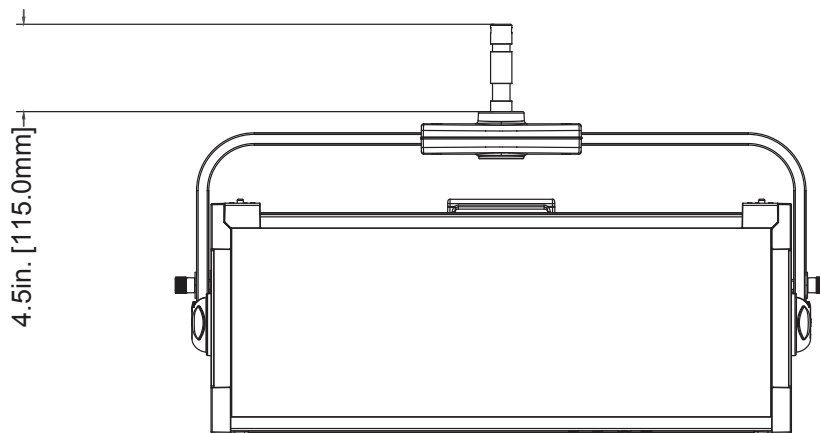

OPTIONAL ACCESSORIES

ORDER CODE	ITEM
KLP103	KL Panel XL
KLP972	KL Panel XL Intensifier Lens
KLP637	KL Panel XL 40° Snap Grid
KLP651	KL Panel XL Snap Bag

FCC STATEMENT

This device complies with Part 15 of the FCC Rules. Operation is subject to the following two conditions: (1) this device may not cause harmful interference, and (2) this device must accept any interference received, including interference that may cause undesired operation.

FCC RADIO FREQUENCY INTERFERENCE WARNINGS & INSTRUCTIONS

This product has been tested and found to comply with the limits as per Part 15 of the FCC Rules. These limits are designed to provide reasonable protection against harmful interference in a residential installation. This device uses and can radiate radio frequency energy and, if not installed and used in accordance with the included instructions, may cause harmful interference to radio communications. However, there is no guarantee that interference will not occur in a particular installation. If this device does cause harmful interference to radio or television reception, which can be determined by turning the device off and on, the user is encouraged to try to correct the interference by one or more of the following methods:

- Reorient or relocate the device.
- Increase the separation between the device and the receiver.
- Connect the device to an electrical outlet on a circuit different from which the radio receiver is connected.
- Consult the dealer or an experienced radio/TV technician for help.



